



# NAVIGATOR X1100

User's Manual

V1.0.0

ZHEJIANG DAHUA VISION TECHNOLOGY CO.,LTD

# Legal Statement

## Copyright

© 2018 ZHEJIANG DAHUA VISION TECHNOLOGY CO.,LTD. All rights reserved.

Any or full contents of the user's manual cannot be copied, transmitted, distributed, partially or wholly, by any means, without the prior written notice of ZHEJIANG DAHUA VISION TECHNOLOGY CO.,LTD.

Dahua or the third party may reserve the right of the product described in this user's manual. Without the prior written approval of the corresponding party, any person cannot (including but not limited to) copy, distribute, amend, excerpt, reverse compile, disassemble, decode, reverse engineering, rent, transfer or sublicense the software.

## Trademark

 and **HDCVI** are the trademarks or registered trademarks of Dahua and its branch companies in various jurisdictions. Other trademarks or company names mentioned are the properties of their respective owners.

## Update and Modification

- In order to enhance the product security and provide better user experience, Dahua may improve the product via software auto update, but Dahua doesn't need to inform in advance and isn't liable to any responsibility.
- Dahua reserves the right to modify any information in this document at any time; the modified contents will be added to the new version without prior announcement. There may be minor differences about some product functions after it is updated.

## Document Overview

The manual is to comprehensively introduce function features, structure parameters, installation, dismounting and flight guide etc. of the product.

## Applied Model

X1100

## Application Object

End users.





## Reading Guide

Chapter No.	Chapter Name	Main Content
1	Product Overview	It is to introduce the function features and application scenarios of the product.
2	Product Component	It is to comprehensively introduce main components of the product. Read the chapter before use; understand product structure and application methods of main components.
3	Flight Preparation	It is to elaborate the complete flow of aircraft unlock before takeoff. Strictly conform to the installation debugging sequence of the chapter, install each component and make initial debugging before first use. If it is not the first time to use the device, you can select the installation content according to the dismounting situation last time. However, confirm that all the components (unnecessary steps excluded) listed in the chapter have been stably installed. Please conform to the operating steps in this chapter strictly and follow the operating sequence.
4	Enable Flight	It is to elaborate the complete flow of aircraft formal launch, landing and locking. Complete the preparation steps listed in Chapter 3. Confirm that all the inspection items, including environment and the device itself, conform to flight requirements before enabling flight. Please operate by strictly conforming to the steps described in the chapter; the operation sequence can't be reversed.
5	End Flight	It is to elaborate the operation steps after aircraft landing. Please operate by strictly conforming to the steps described in this chapter; the operation sequence can't be reversed.

6	Upgrade	It is to introduce upgrade methods and points of attention.
7	Appendix 1	It is to introduce the technical parameters.
8	Appendix 2	It is to introduce the indicator definition of the aircraft.
9	Appendix 3	It is to introduce the matching method among the components.
10	Appendix 4	It is to list possible problems and solutions when using the product.

## Symbol Definition

The following symbol may appear in the document. Please refer to the table below for the respective definition.

Symbol	Note
 <b>Danger</b>	It indicates a potentially hazardous situation which, if not avoided, could result in death or serious injury.
 <b>Warning</b>	It indicates a moderate or low level of potential danger which, if not avoided, could result in minor or moderate injury.
 <b>Caution</b>	It indicates a potential risk that, if ignored, could result in damage to device, degraded performance, or unpredictable results.
 <b>Tips</b>	It means that it can help you to solve some problems or save your time.
 <b>Note</b>	It means the additional information, which is the emphasis and supplement of the main body.

## Document Material

The product includes the following document materials. Please search according to your requirements:

- *Quick Start Guide*

It applies to the first simple flight. Please refer to *User's Manual* for operation details when it is used for the second time or it has to use some other advanced functions.

Check the paper material in the packaging box or log in [www.dahuasecurity.com](http://www.dahuasecurity.com) to obtain the *User's Manual*.

- *User's Manual* (this document)

It comprehensively introduces the product function features, structure parameters, installation, dismounting and flight guide etc.

Log in [www.dahuasecurity.com](http://www.dahuasecurity.com) to obtain the *User's Manual*.

## Revision Record

No.	Version No.	Revision Content	Release Date
1	V1.0.0	First release	2018.02.13

# Important Safeguards and Warnings

The following description is the correct application method of the device. Please read the manually carefully before use, in order to prevent danger and property loss. Strictly conform to the manual during application and keep it properly after reading.

## Danger

- Please operate the aircraft in the environment which meets flight conditions, and keep away from no-fly zone.
- After unlocking, operators shall keep at least 5m away from the aircraft.

## Warning

- Please transport, use and store the product and all its components in the environment which satisfies the requirements.
- Please strictly conform to operation flows described in the manual when dismantling the device. Please do not dismantle other components privately.

## Caution

- Please do not touch the lens of PTZ camera directly. Use hair drier to remove the dust or dirt from the lens surface.
- Please operate the device by strictly conforming to the steps described in the manual; the operation sequence can't be reversed.
- Get to know local laws and regulations before using the aircraft. Please apply to local authorities for flight permission if necessary.
- For the first flight, please adopt loiter mode (before takeoff, it is suggested that GPS satellites are  $\geq 12$  and horizontal dilution of precision (HDOP) is  $\leq 1$ ).
- Please make sure that the device antenna has been properly installed before enabling the power of remote control or aircraft. Otherwise, it may cause damages to internal module or shorten the control distance.

## Flight Environment

### Warning

Please make flight in the environment which meets the following conditions:

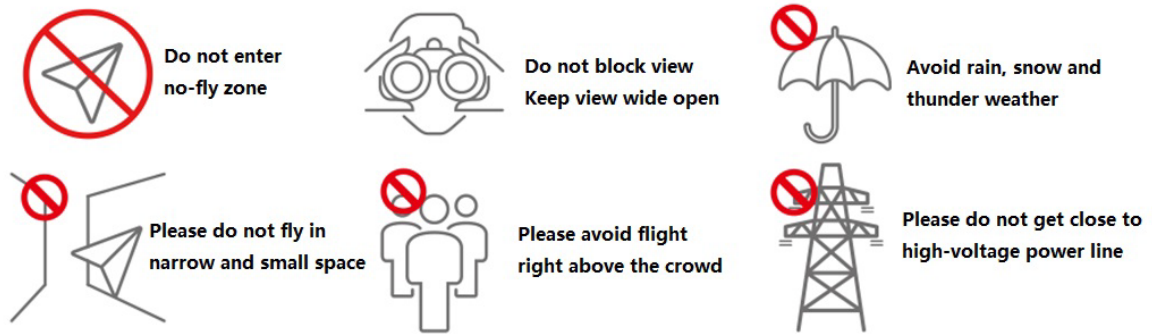

- Keep away from no-fly zone; please do not enter no-fly zone.
- Keep view wide open; make sure the device is flying within field of view; please do not block field of view.
- Please do not fly the aircraft in rain, snow and thunder weather.
- Please do not fly in narrow and small space.
- Try not to fly right above the crowd, in order to prevent personal injury.
- Please do not get close to high-voltage power line. Keep more than 10m distance.

## Power Requirement

### Caution

- The product shall use electric wires (power wires) recommended by this area, which shall be used within its rated specification!
- Products with category I structure shall be connected to grid power output socket, which is equipped with protective grounding.
- Please conform to local electrical safety standards strictly.
- Before operation, please check whether power supply is correct.
- Please use power supply that meets SELV (safety extra low voltage) requirements, and supply power with rated voltage that conforms to Limited Power Source in IEC60950-1. For specific power supply requirements, please refer to device labels.
- Prevent power cord from being trampled or pressed, especially the plug, power socket and the junction extruded from the device.

## Battery Points of Attention

### Warning

- It has to use the exclusive power adapter provided by Dahua Technology to charge the device. Otherwise, it may damage the battery or lead to other unpredictable consequences.
- Charge the device at a temperature between 0 and 50°C.
- Distinguish positive and negative poles when charging the device, to prevent short circuit.
- Charge and discharge at least once every month; prohibit storing the device without electricity.
- Please do not place the device close to fire source or inflammables.
- Please do not charge and discharge the device in unattended conditions.
- Please do not use undesignated battery to the device.

- Please do not dismantle and destroy the battery without permission; water is not allowed to enter the device; man-made damages are not covered by warranty.
- Please do not throw the battery into fire or expose it to high-temperature environment.
- Please do not dismantle, modify or deform the battery.
- Avoid short circuit between positive and negative contacts (please do not place the battery together with the objects such as necklace and hairpin etc. when carrying or storing the battery).
- Please replace new battery timely when it is damaged. Please contact local relevant agency to deal with damaged battery properly, in order to prevent accidents.
- Please charge the battery or discharge it to 50%~60% remaining capacity if it won't be used for a long time, and place it in a dry and cool environment.
- If the battery leaks and the liquid enters eyes accidentally, please do not rub your eyes; wash your eyes with clean water and see a doctor immediately.

### Caution

- It is normal that the battery heats up after it is running for a period of time, because the discharge power is quite big.
- It is normal that the battery heats up when it is being charged.
- The cycle times of power battery is 300 in normal application situation.
- During charging of power battery, charging is completed when the charger displays “FULL” and beeps continuously. Don't take down batteries before charging is completed.

## Application Environment Requirements

- Please do not aim the PTZ at strong light (such as lighting, sunlight and so on).
- Please transport, use and store the device within the allowed humidity and temperature range.
- Please do not let any liquid flow into the device.
- Please do not block the device ventilation.
- Please do not press, vibrate or soak the device.
- Please pack the device with original package or material with equivalent quality.

## Operation and Maintenance Requirements

### Warning

- Please do not dismantle the device privately.
- Please do not touch sensor CCD or CMOS directly; use hair drier to remove dust or dirt from the lens surface.
- Please use soft dry cloth or clean soft cloth to dip a little mild detergent to clean the device.
- Please do not touch or wipe the lens surface directly.
- Please use the accessories provided by manufacturer and it shall be installed and repaired by professional staffs.
- Please avoid laser beam radiation to the surface when using laser beam device.
- Please do not provide two or more power supply modes to the device at the same time; otherwise, it may damage the device.
- Max 1 aircraft is allowed to fly in the same area at the same time.



- Please make sure that there is no occlusion above the flight.

## Special Announcement

- This manual is for reference only. Please refer to the actual product for more details.
- The user's manual, software and firmware will be regularly updated according to the product upgrade without prior announcement.
- The user shall undertake any losses resulting from violation of guidance in the document.
- The document may include technically inaccurate contents, inconsistencies with product functions and operations, or misprint. Final explanations of the company shall prevail.
- Interface in this manual may be slightly different from actual interface. Please refer to actual interface for details.
- Other trademarks or company names mentioned in the document belong to the respective owners.

# Table of Contents

<b>Legal Statement</b> .....	<b>I</b>
<b>Preface</b> .....	<b>II</b>
<b>Important Safeguards and Warnings</b> .....	<b>V</b>
<b>1 Product Introduction</b> .....	<b>1</b>
1.1 Overview .....	1
1.2 Functional Features .....	1
<b>2 Structure</b> .....	<b>4</b>
2.1 Aircraft .....	4
2.1.1 Product Dimensions.....	4
2.1.2 Structural Component.....	6
2.2 Airborne Device.....	7
2.2.1 The 2 MP Visible Light PTZ Camera.....	8
2.2.2 Structural Component of 2 MP Visible Light PTZ Camera.....	10
2.3 Remote Control .....	11
2.3.1 Dimensions .....	11
2.3.2 Structural Component.....	12
2.3.3 Buttons.....	16
2.3.4 Operation Interface .....	18
<b>3 Flight Preparation</b> .....	<b>27</b>
3.1 Unpack .....	27
3.2 Check Remaining Power .....	27
3.2.1 Aircraft.....	28
3.2.2 Remote Control.....	29
3.3 Charging.....	30
3.3.1 Aircraft Battery Charging .....	30
3.3.2 Remote Control Charging.....	31
3.4 Prepare Airborne Device.....	31
3.4.1 Demount PTZ Camera .....	32
3.4.2 Install PTZ Camera.....	32
3.5 Prepare Aircraft .....	33
3.5.1 Unfold Arm .....	33
3.5.2 Open Antenna.....	33
3.5.3 Install Aircraft Battery .....	34
3.6 Prepare Remote Control .....	34
3.6.1 Install Micro SD Card.....	34
3.6.2 Open Antenna.....	35
3.6.3 Enable Remote Control Power .....	35
3.6.4 Confirm Remote Control Mode.....	36
3.6.5 Set Quick Operation .....	36
3.7 Enable Aircraft Power .....	42
3.8 Check and Debugging .....	42

3.8.1 Remote Control Calibration .....	43
3.8.2 Accelerometer Calibration .....	43
3.8.3 Initialization Failure .....	44
3.8.4 Geomagnetic Abnormality .....	45
3.8.5 GPS Satellites Insufficiency.....	47
<b>3.9 Install Propellers.....</b>	<b>47</b>
<b>4 Enable Flight.....</b>	<b>49</b>
<b>4.1 Flight Mode .....</b>	<b>49</b>
<b>4.2 Manual Mode .....</b>	<b>50</b>
4.2.1 Introduction to Manual Flight Flow .....	50
4.2.2 Unlock Flight Control .....	50
4.2.3 Manual Takeoff .....	51
4.2.4 Manual Flight Control .....	52
4.2.5 Manual RTH and Landing.....	53
4.2.6 Manual Locking.....	54
<b>4.3 Intelligent Mode.....</b>	<b>55</b>
4.3.1 Intelligent Flight Mode .....	55
4.3.2 Intelligent Locking Mode.....	59
4.3.3 Intelligent Operation.....	60
<b>4.4 Intelligent Protection Mechanism.....</b>	<b>62</b>
4.4.1 Low Battery .....	62
4.4.2 Out of Control .....	62
<b>4.5 Remote Control Setting.....</b>	<b>62</b>
4.5.1 Remote Button User-defined.....	62
4.5.2 Flight Control Settings .....	63
4.5.3 Preview Settings .....	66
4.5.4 Camera Settings .....	67
4.5.5 General Settings .....	70
<b>5 End Flight.....</b>	<b>75</b>
<b>5.1 Turn off Power.....</b>	<b>75</b>
<b>5.2 Remove Aircraft Battery.....</b>	<b>76</b>
<b>5.3 Dismantle Airborne Device .....</b>	<b>77</b>
<b>5.4 Fold Aircraft.....</b>	<b>77</b>
<b>5.5 Copy Video of Camera Micro SD Card.....</b>	<b>79</b>
<b>5.6 Remove Other Components .....</b>	<b>79</b>
<b>6 Upgrade and Update.....</b>	<b>80</b>
<b>6.1 Firmware Update.....</b>	<b>80</b>
<b>6.2 Remote Control Update .....</b>	<b>80</b>
6.2.1 APP Update .....	80
6.2.2 Download and Update Offline Map of Remote Control.....	81
<b>Appendix 1 Main Technical Parameters .....</b>	<b>82</b>
<b>Appendix 2 Aircraft State Indicator.....</b>	<b>85</b>
<b>Appendix 3 System Pairing.....</b>	<b>87</b>
<b>Appendix 4 FAQ .....</b>	<b>89</b>
Appendix 4.1 FAQ and Solutions of Aircraft.....	89
Appendix 4.2 FAQ and Solutions of Remote Control.....	89
Appendix 4.3 FAQ and Solutions of Airborne Device.....	89



# 1 Product Introduction

## 1.1 Overview

This product is a hex-rotor drone designed for public security, transportation, firefighting, border defense, agriculture, forest and energy source fields. It provides integrated solutions of aerial video surveillance.

This product consists of aircraft, airborne device and remote control.

- Aircraft: It consists of navigation system, flight control system and power system.
- Airborne device: It consists of the PTZ control system and mission device.
- Remote control: It consists of the remote control system, data chain and software.

## 1.2 Functional Features

### Integrated Design

- The aircraft adopts integrated design and neat appearance. Only the propeller shall be dismantled and installed.
- The remote control integrates the remote control and touch screen together. It is easy to operate and has clear indicator.

### Folded Packages

- Arm can be folded repeatedly.
- Antennas can be folded repeatedly, suitable to be carried, transported and stored.

### Quick Dismantling

- The propeller adopts quick dismantling structure.
- It is easy to open or fold arm and antenna.
- The PTZ camera adopts quick dismantling structure. Installation screws are secured on the shock absorber plate, in order to prevent them from being lost.

### HD Video

- The shock absorber board and shock absorber ball work together to guarantee PTZ camera stability.
- Industrial 30x optical zoom visible light camera is optional, with professional HD video

- effect.
- IR thermal camera is optional, suitable for special environments such as fire scene or night environment, so as to guarantee clear video and high restoration thermal images.
- The remote control has snapshot button and record button, which are easy to operate and instantly start snapshot and record function.

## **Accurate Positioning**

Built-in GSP system ensures that positioning is accurate and real-time.

## **Wireless Transmission**

- Aircraft has 4 antennas. Connect the remote control and image transmission device to send and receive radio wave signals.
- The remote control has 3 antennas. Connect the aircraft to send and receive radio wave signals.

## **Low Electric Quantity Protection**

When electric quantity is lower than estimated safe return value, trigger low electric quantity protection automatically, including alarm, return home and landing.

## **Intelligent Battery**

- Display remaining electric quantity: Battery has built-in power indicator light.
- Balanced charging protection function: Automatically balance the battery cell voltage to protect battery.
- Overcharge protection function: Battery automatically stops charging when the voltage is full.
- Sleep protection function: Battery automatically goes to sleep state when there is no operation within 5 minutes.
- Charging temperature protection function: The battery charging temperature ranges from 0°C to 50°C. Once the temperature is too high, battery automatically stops charging; otherwise, it may result in battery damage.
- Communication: The remote control can get remaining capacity and voltage information.

## **Flight Control**

- The aircraft adopts hex-rotor power system. It can switch among several flight modes and control the flight direction flexibly.
- Support 14,500g maximum take-off weight.
- Support binocular obstacle avoidance, optical flow positioning, RTK and protection in case of broken propeller.

## **Electronic Fence (e-fence)**

- Support e-fence function; prevent the aircraft from leaving the specified flight zone.

- Support customized e-fence settings.

# 2 Structure

This product mainly consists of aircraft, airborne device and remote control. This chapter introduces the structures of these 3 components. The detailed operations will be introduced in “3 Flight Preparation”.

## Note

All figures listed below and all dimensions listed here for reference only. The figure and the dimensions may be slightly different from the user data due to measurement position, measurement accuracy and position indication. Please refer to the actual product for detailed information.

## 2.1 Aircraft

This section is introduced when the propeller is installed completely and the whole device is unfolded. Please refer to Chapter 3 for details.

### 2.1.1 Product Dimensions

Unit is mm.

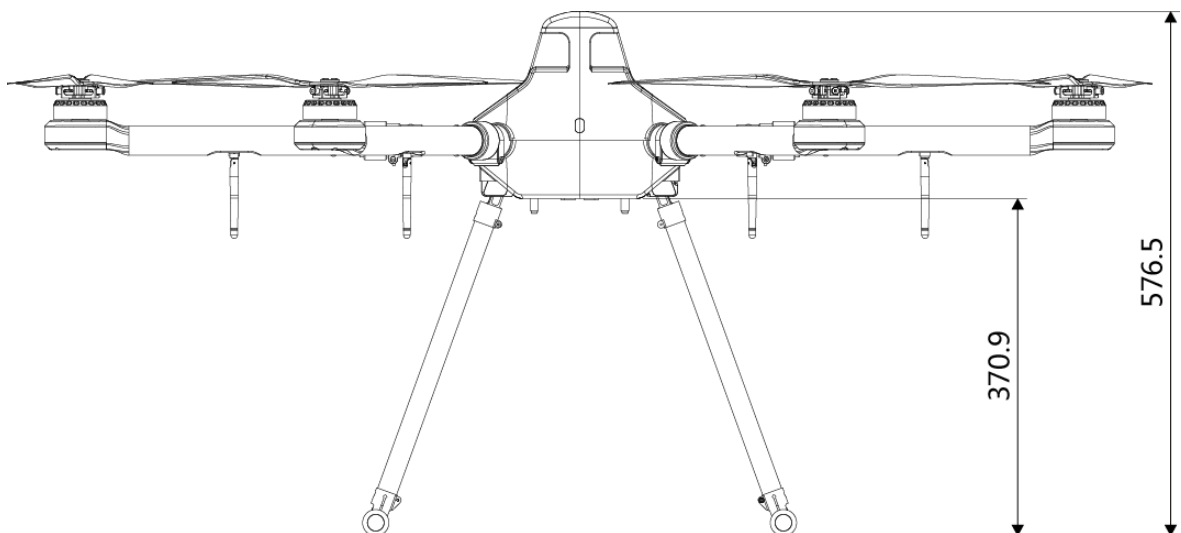

Figure 2-1



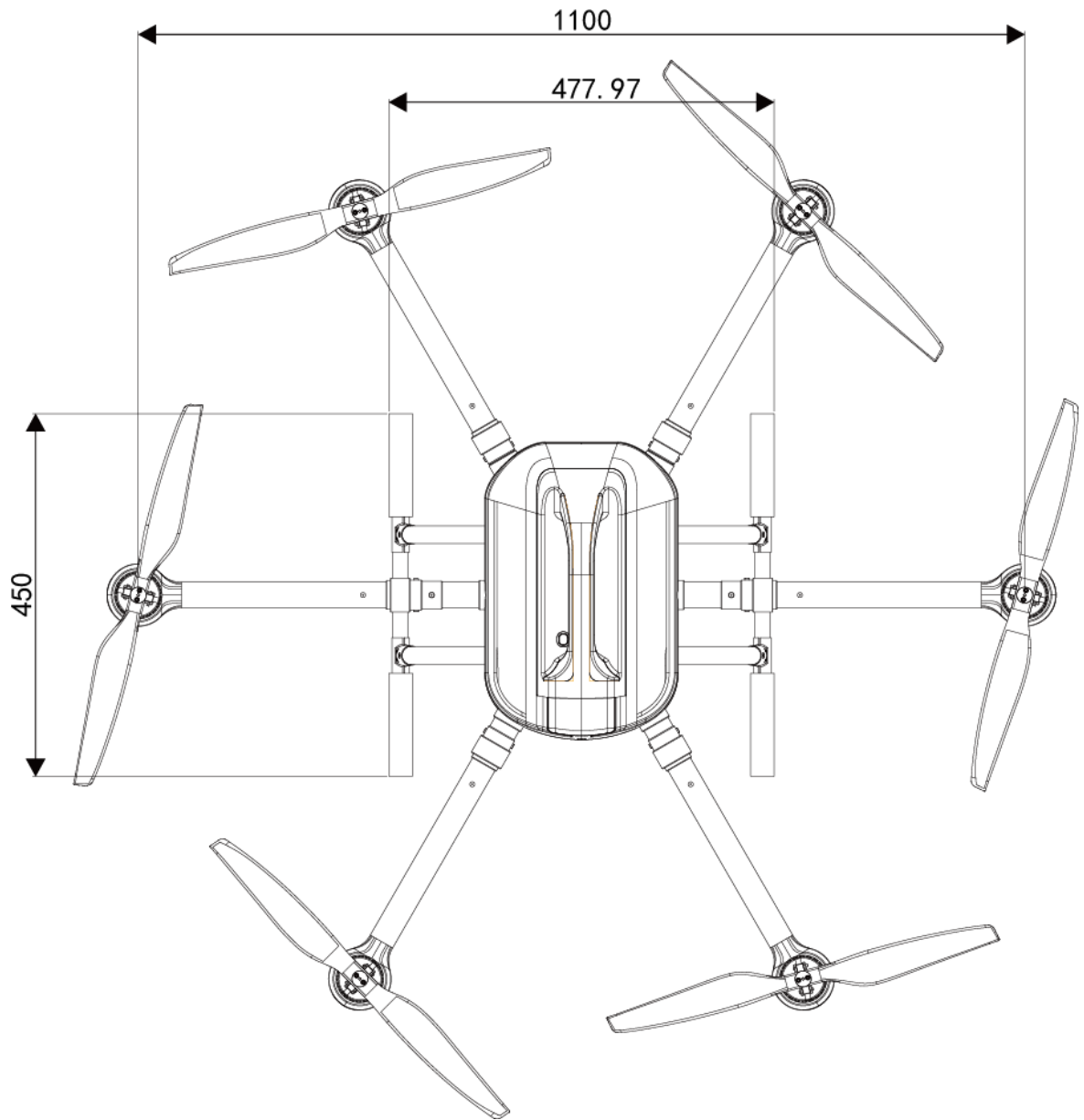

Figure 2-2

## 2.1.2 Structural Component

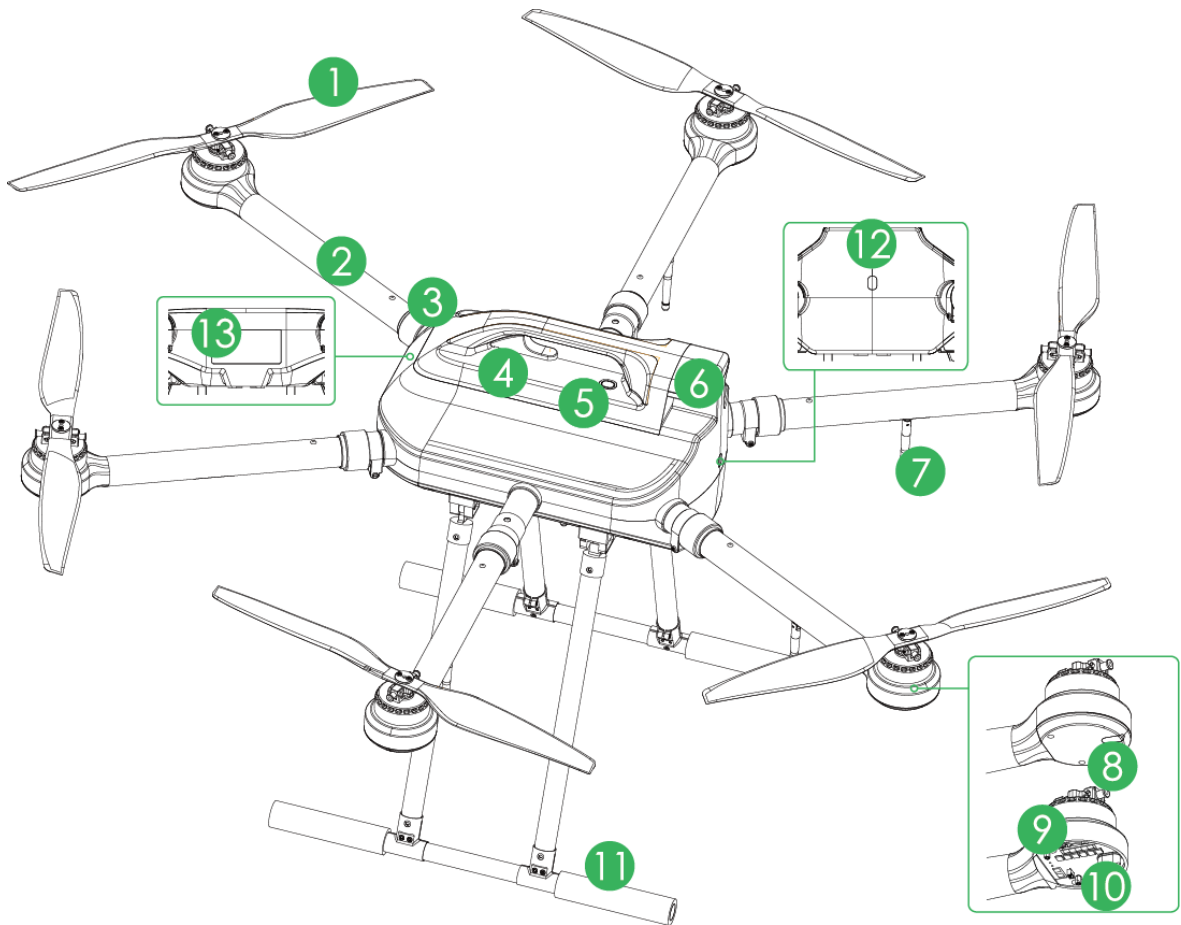



Figure 2-3

No.	Name	Function
1	Propeller	High-speed revolution to turn the brushless motor power to propulsive force. There are 3 pairs of propellers (3 CW propellers and 3 CCW propellers) with different structures. Please install propellers according to the actual situation.
2	Arm	Fold and unfold.
3	Protective cover of propeller	Fix the horizontally unfolded arm.
4	Battery buckle	Dismantle and install the battery. <ul style="list-style-type: none"> <li>When it is opened, battery can be dismantled from the device and replaced.</li> <li>When it is closed, the battery cannot be dismantled from the device.</li> </ul> <p> <b>Caution</b></p> <p>After the battery is installed into the aircraft, battery buckle shall be closed!</p>



No.	Name	Function
5	Power switch (with indicator)	Built-in indicator. After the aircraft is power on, red indicates power-on state, while green indicates remaining battery.
6	Empennage	Built-in GPS and electronic compass.
7	Antenna	Fold or unfold. <ul style="list-style-type: none"> <li>• 2 antennas are to receive the remote control signal.</li> <li>• 2 antennas are for wireless image transmission.</li> </ul>
8	Motor control panel indicator	Display red and green. <ul style="list-style-type: none"> <li>• Two adjacent indicators are normally on in red; their middle part indicates aircraft nose.</li> <li>• Four adjacent indicators are normally on in green; their middle part indicates aircraft tail.</li> </ul>
9	Motor	Drive propeller rotation.
10	Motor speed controller	With sine wave driving, have excellent acceleration and deceleration performance.
11	Landing gear	Control the landing gear to open or fold with remote control buttons.
12	Aircraft state indicator	There are two modes: normally on and flashing. It displays five colors: red, yellow, blue, green and purple, to indicate system state, flight mode, upgrade state and etc.  <b>Note</b> Refer to Appendix 2 for indicator light information and definition.
13	Heat dissipation module (cooling fin)	Built-in binocular heat dissipation module (cooling fin).  <b>Note</b> This module has different structures depending on device configurations. Please refer to actual product.

Table 2-1

## 2.2 Airborne Device

### Note

- This part takes visible light PTZ camera and IR thermal PTZ camera as an example, and introduces airborne device.
- For detailed info about various airborne device, please refer to their user's manuals and quick start guides.

The aircraft supports to carry 2 MP visible light PTZ camera and multiple airborne devices.

# 2.2.1 The 2 MP Visible Light PTZ Camera

Unit is mm.

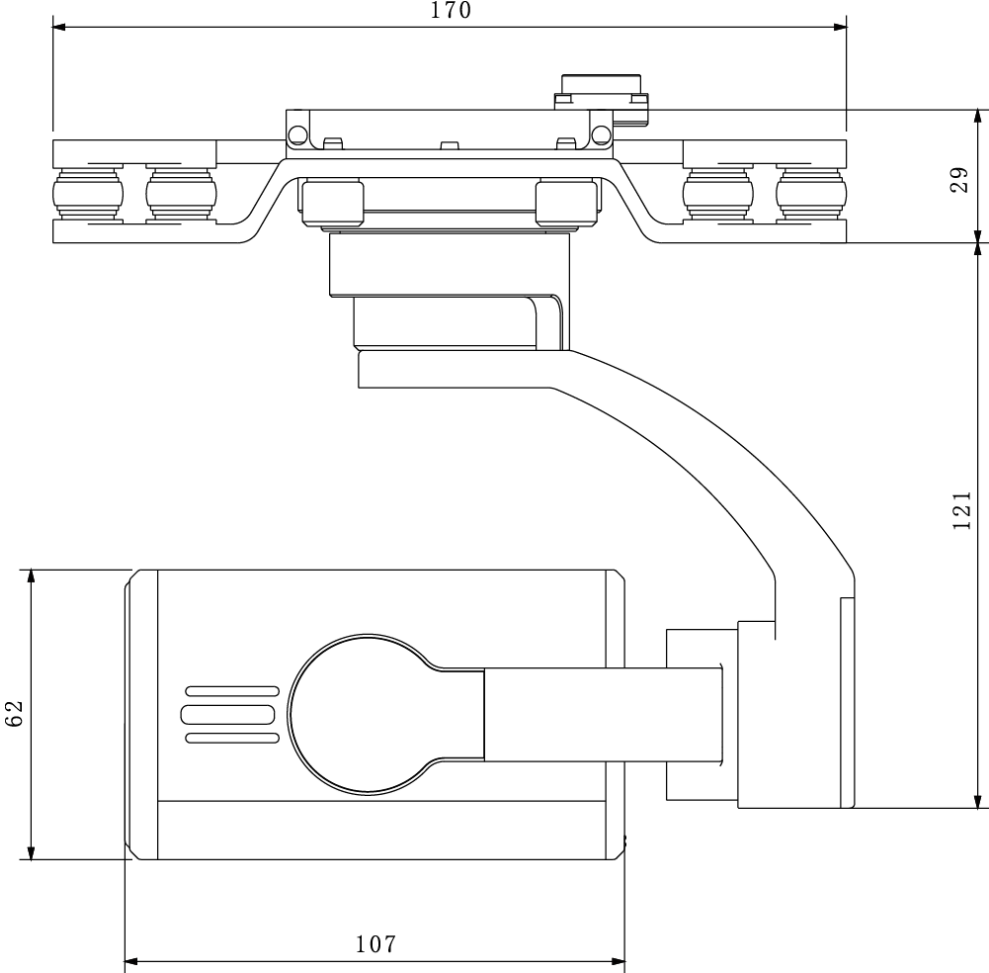

Figure 2-4

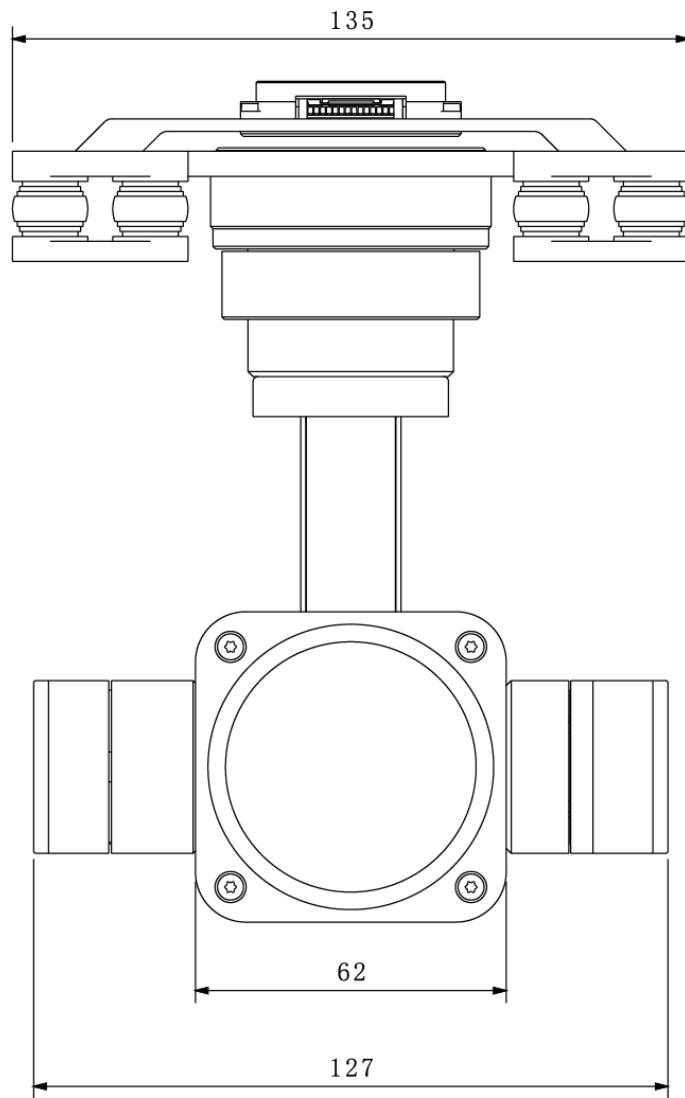

Figure 2-5

## 2.2.2 Structural Component of 2 MP Visible Light PTZ Camera

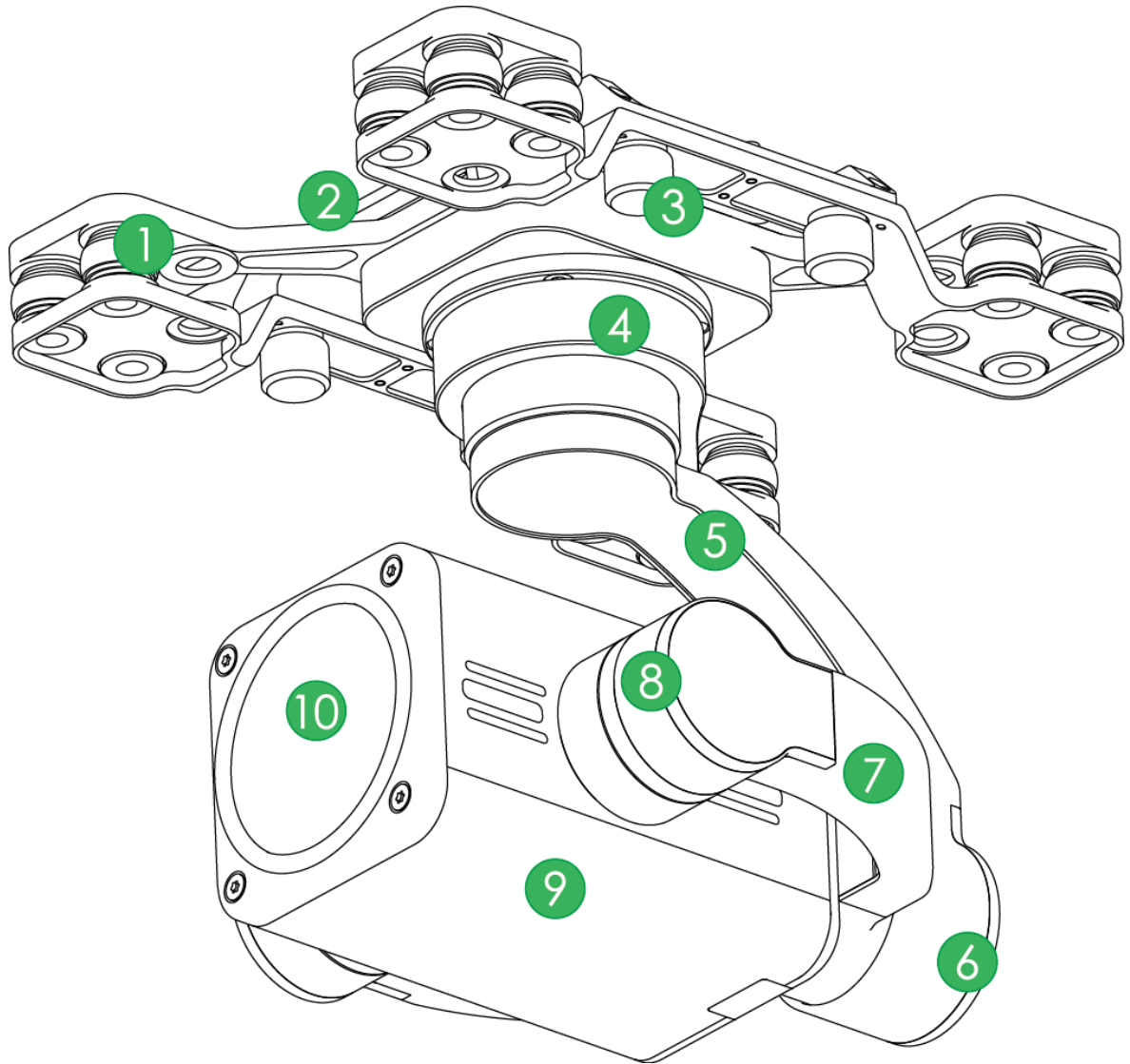

Figure 2-6

No.	Name	Function
1	Shock absorber ball	Reduce PTZ camera vibration during the flight, to get clearer video.
2	Shock absorber board	
3	Installation screw	Secure the PTZ camera on the aircraft.
4	Course motor	Control horizontal direction of the camera.
5	Course rotation arm	
6	Roll motor	Control horizontal inclination angle of the camera.
7	Roll rotation arm	
8	Pitching motor	Control vertical pitching angle of the camera.
9	Camera	Take pictures.
10	Lens	

Table 2-2

# 2.3 Remote Control

## 2.3.1 Dimensions

Unit is mm.

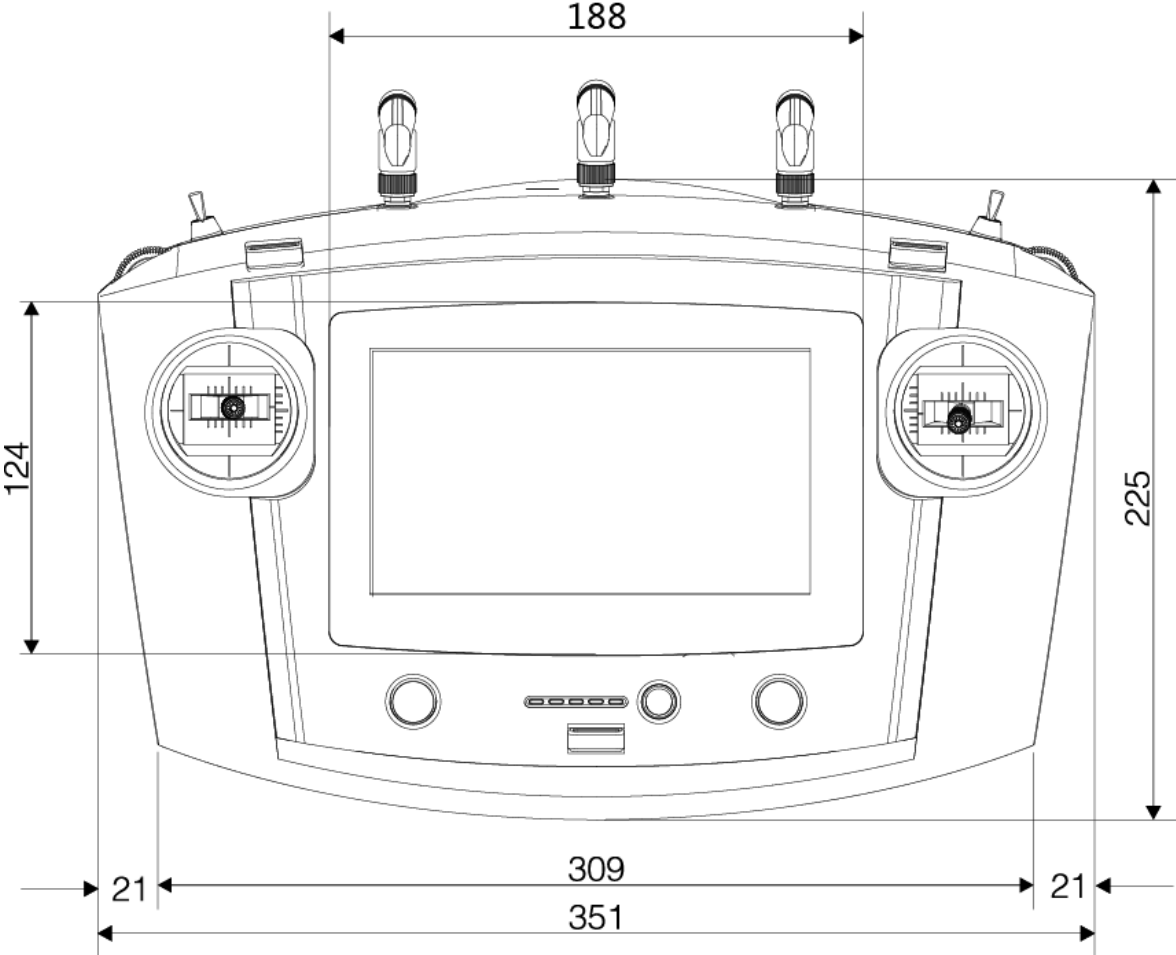

Figure 2-7

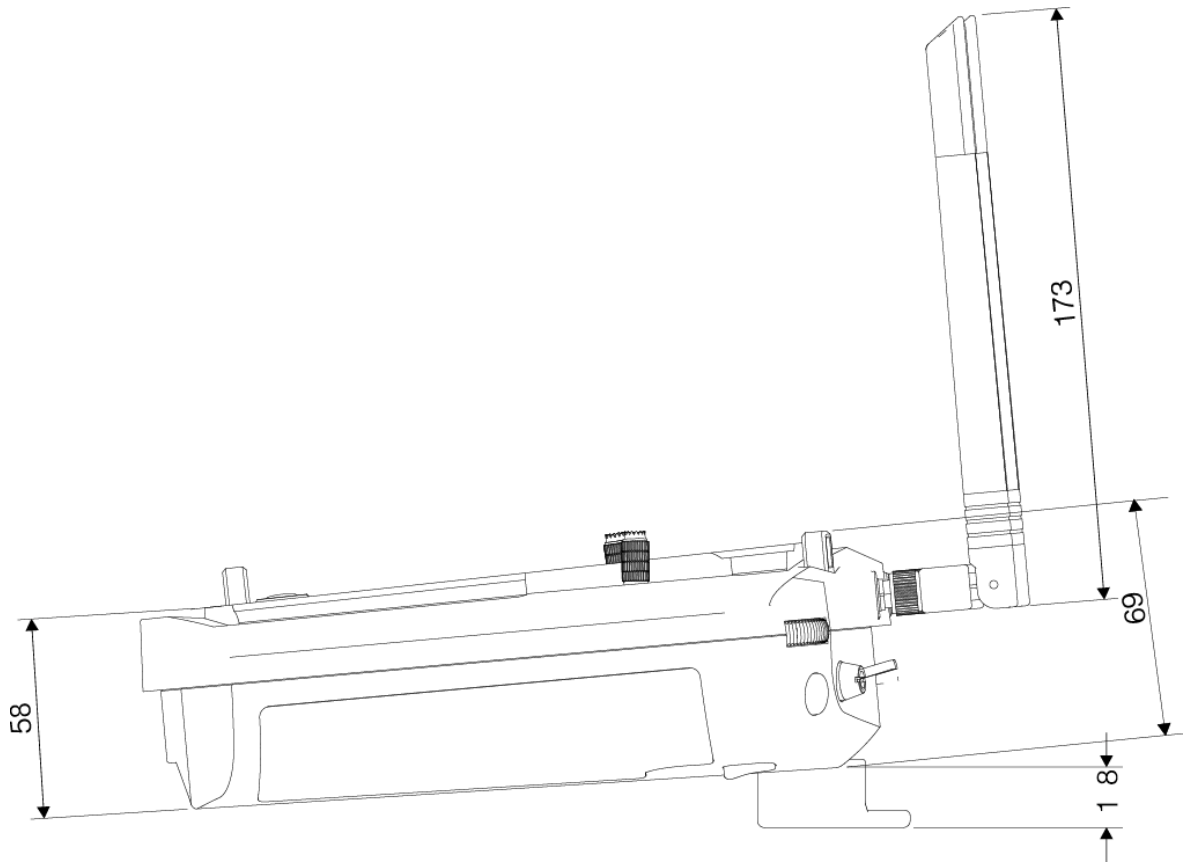

Figure 2-8

### 2.3.2 Structural Component

Front panel, side panel and rear panel of the remote control are shown in Figure 2-9, Figure 2-10 and Figure 2-11.



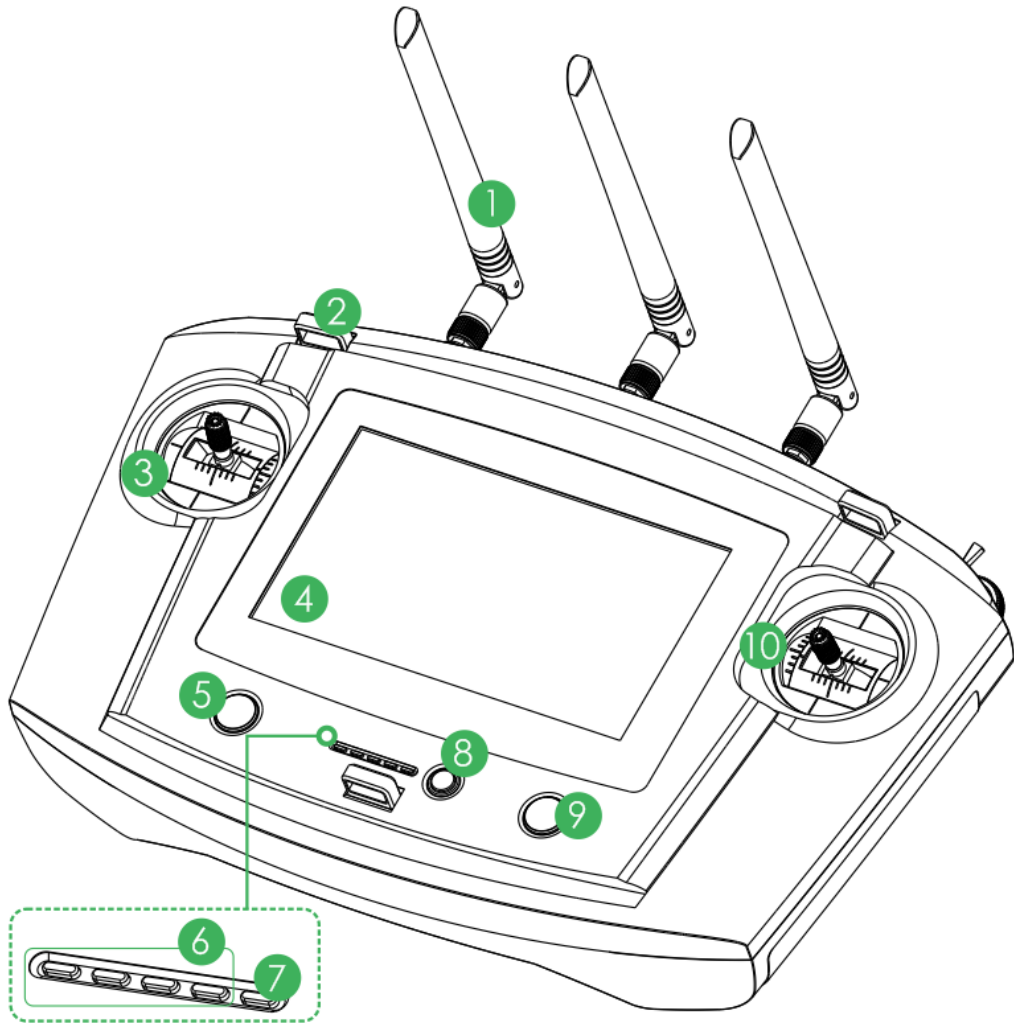

Figure 2-9

No.	Name	Function
1	Antenna	Establish the remote control relationship with the aircraft and receive images. One silver antenna is installed in the middle, while two yellow antennas are installed at both sides.
2	Hanger	Fix the hanger belt.
3	Left control joystick	Control the aircraft flight state.
4	Touch screen	Set parameters and preview the video.
5	Landing gear button	Control the landing gear.
6	Battery indicator	Each bar represents 25% battery power.
7	Charging indicator	Indicator light is on when connecting power to the charging port. <ul style="list-style-type: none"> <li>● Red light is normally on: charging.</li> <li>● Green light is normally on: charging is finished.</li> </ul>
8	One-click return button	Control aircraft to return home automatically.
9	One-click takeoff/landing button	Control aircraft takeoff or landing with one click. Takeoff height is 2m.

No.	Name	Function
10	Right joystick control	Control the aircraft flight state.

Table 2-3

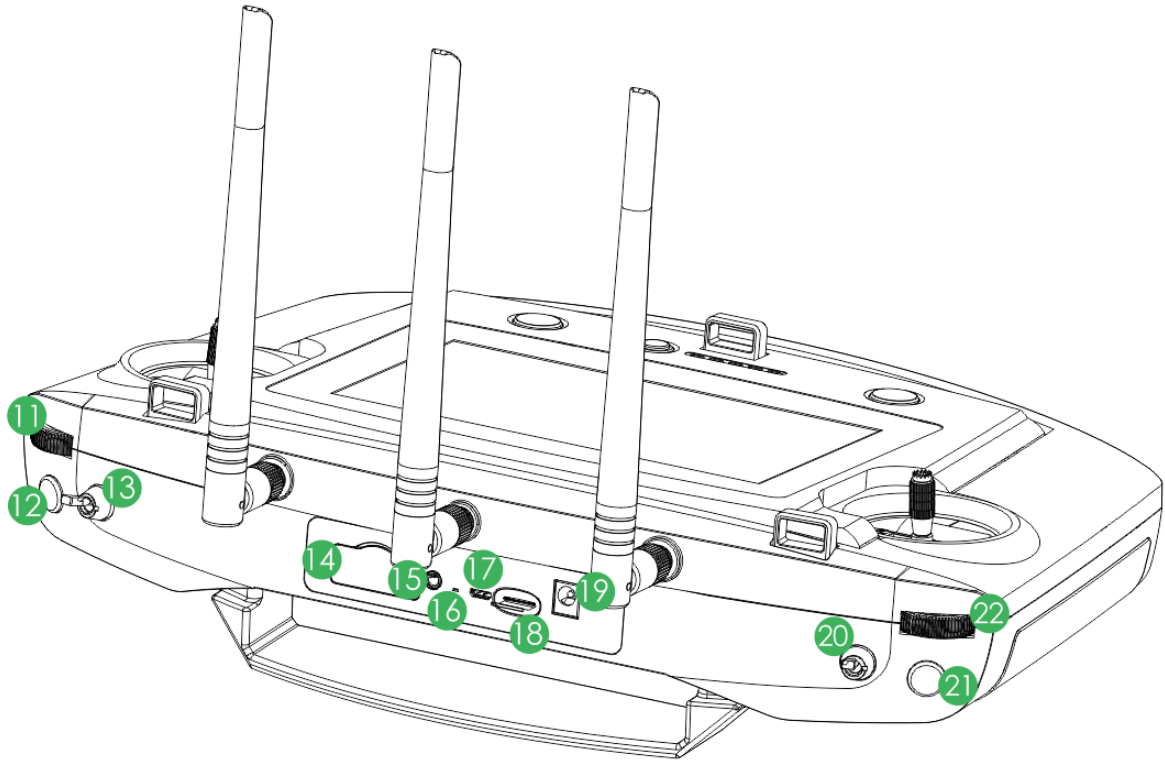

Figure 2-10

No.	Name	Function
11	PTZ course scroll wheel	Control horizontal shooting angle of camera lens.
12	Snapshot	Press this button shortly to snapshot present image.
13	Flight mode lever	3-level lever to select flight mode. <ul style="list-style-type: none"> <li>● Upper level: intelligent flight mode. The aircraft flights automatically according to the specified course.</li> <li>● Middle level: flight at the specified height. When the throttle lever is at the central mode, the aircraft flights at the same height automatically.</li> <li>● Lower level: flight at the specified position. When all levers are at the central mode, the aircraft hovers at the same position.</li> </ul>
14	4G SIM slot	Support 4G function.
15	Audio output port	Connect to earphone, sound box and etc. It is to play audio.
16	Reset button of remote control	Reserved.
17	Micro USB port	Insert data cable to connect PC. It is to transmit the data to the PC.

No.	Name	Function
18	SD slot	<ul style="list-style-type: none"> <li>● Insert micro SD card: The micro SD card with the chip is facing down. Insert the card to the slot horizontally.</li> <li>● Remove micro SD card: Press micro SD card inwards, so micro SD card pops up a little bit, and can be pulled out.</li> </ul>
19	Power port	Input DC 12V power.
20	PTZ mode lever	2-level lever. It is to select PTZ mode. <ul style="list-style-type: none"> <li>● Upper level: Course following mode. The PTZ camera angle changes with aircraft flight direction.</li> <li>● Lower level: Course locking mode. No matter what the aircraft flight angles are, the PTZ camera always faces the same degree to shoot.</li> </ul>
21	Record button	Press this button shortly to start recording, and press it again to stop recording.
22	PTZ pitch scroll wheel	Control vertical shooting angle of camera lens.

Table 2-4

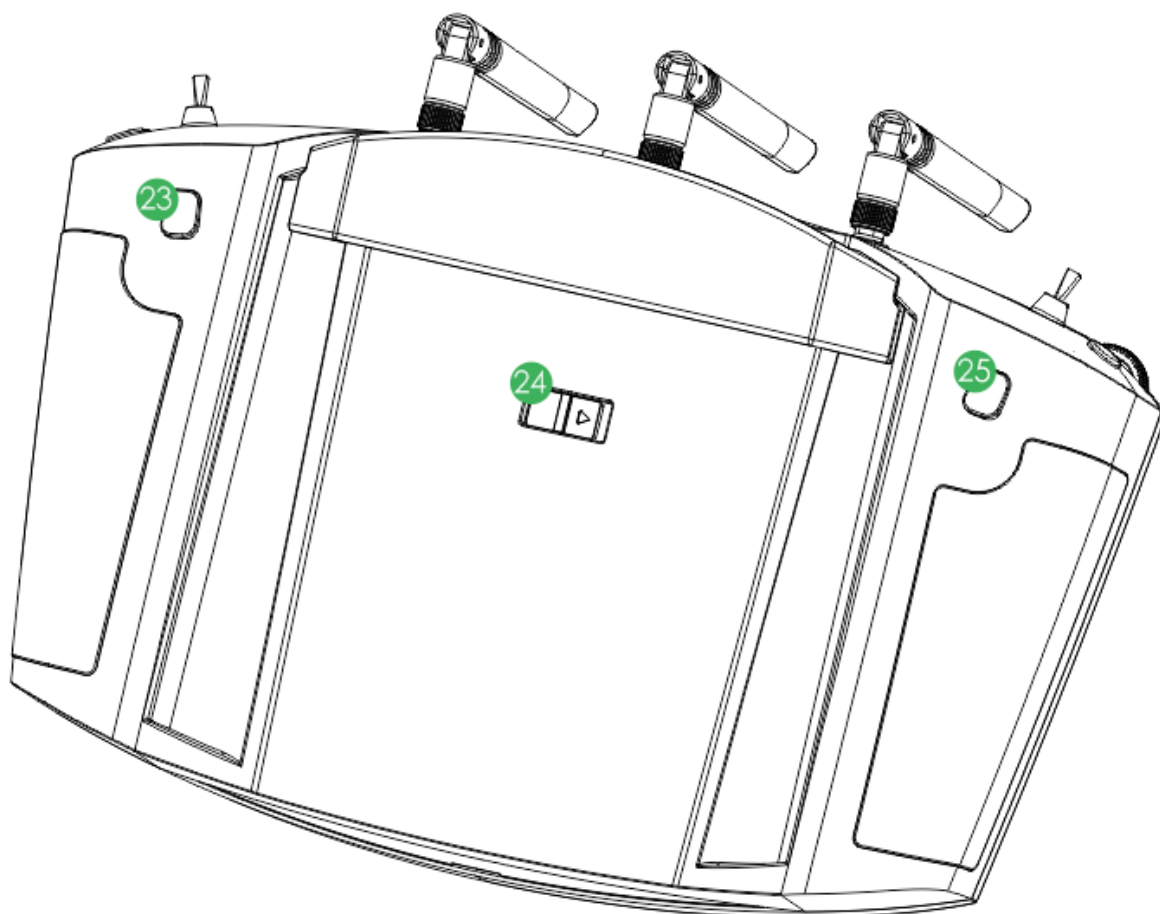

Figure 2-11

No.	Name	Function
23	Zoom in button	<ul style="list-style-type: none"> <li>● Press it for a short time, to zoom in the camera.</li> <li>● Press it for a long time, to zoom in until the camera reaches the maximum magnification.</li> </ul>
24	Power switch	Turn on or turn off the remote control.

No.	Name	Function
25	Zoom out button	<ul style="list-style-type: none"> <li>● Press it for a short time, to zoom out the camera.</li> <li>● Press it for a long time, to zoom out until the camera reaches the minimum magnification.</li> </ul>

Table 2-5

## 2.3.3 Buttons

### Note

Refer to Chapter 4 for the joystick and flight mode lever button information.

### 2.3.3.1 Scroll Wheel

#### Note

Besides “PTZ Course Scroll Wheel” and “PTZ Pitching Scroll Wheel” of remote control, control PTZ “PZT Center” and “PTZ 90°” through “State Bar > Quick Operation > PTZ”. Please refer to “3.6.5.2 PTZ” for details.

- PTZ course scroll wheel: control horizontal shooting angle of camera lens, as shown in Figure 2-12.
  - ◇ Scroll wheel turns to the left: PTZ turns to the left.
  - ◇ Scroll wheel turns to the right: PTZ turns to the right.

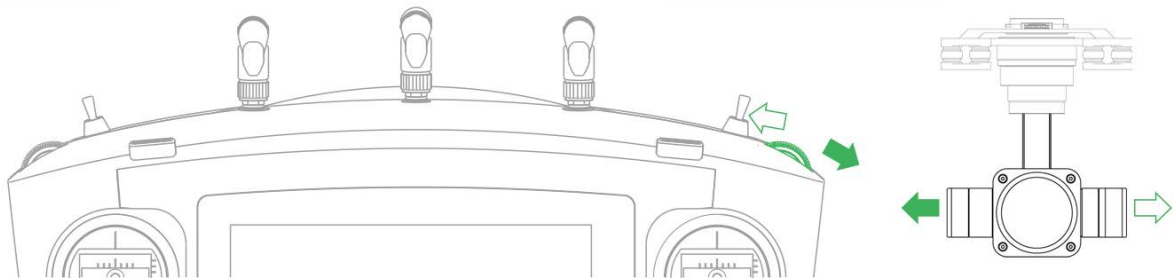

Figure 2-12

- PTZ pitching scroll wheel: control vertical shooting angle of camera lens, as shown in Figure 2-13.
  - ◇ Scroll wheel turns to the left: camera lens turns downwards.
  - ◇ Scroll wheel turns to the right: camera lens turns upwards.

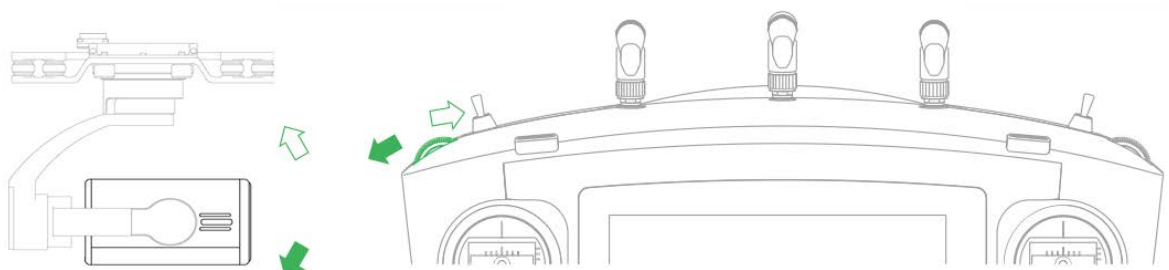

Figure 2-13

### 2.3.3.2 PTZ Mode Lever

Shooting direction of PTZ camera is controlled with PTZ mode lever, as shown in Figure 2-14.

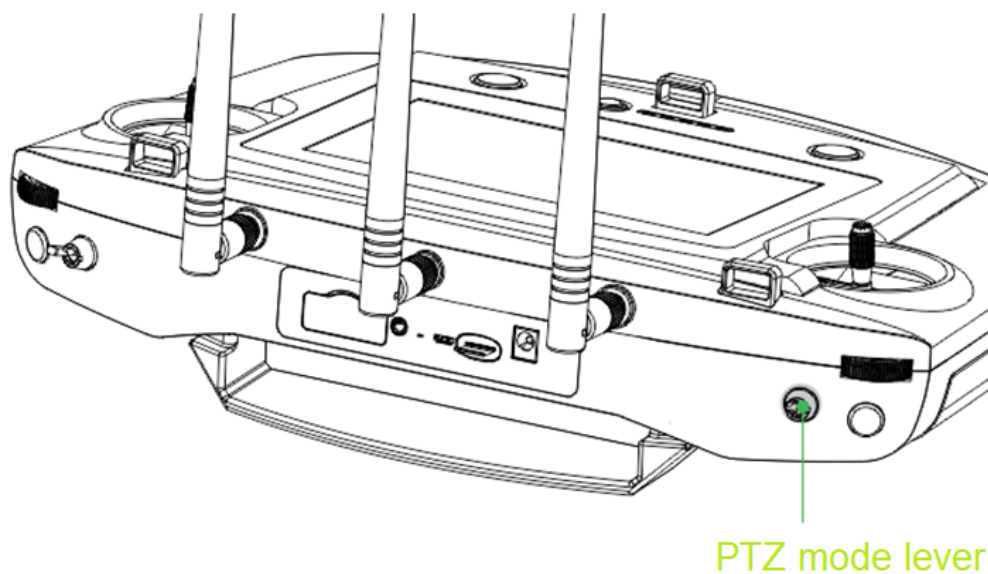

Figure 2-14

2-level lever:

- Upper level: Course following mode. Shooting angle of PTZ camera changes with aircraft flight direction.
- Lower level: Course locking mode. No matter what the aircraft flight angles are, the PTZ camera always faces the same degree to shoot.
- Lever returns to the center: start from any position, move the lever for three times continuously. Shooting angle of PTZ camera will be consistent with aircraft flight direction.

### 2.3.3.3 Shooting

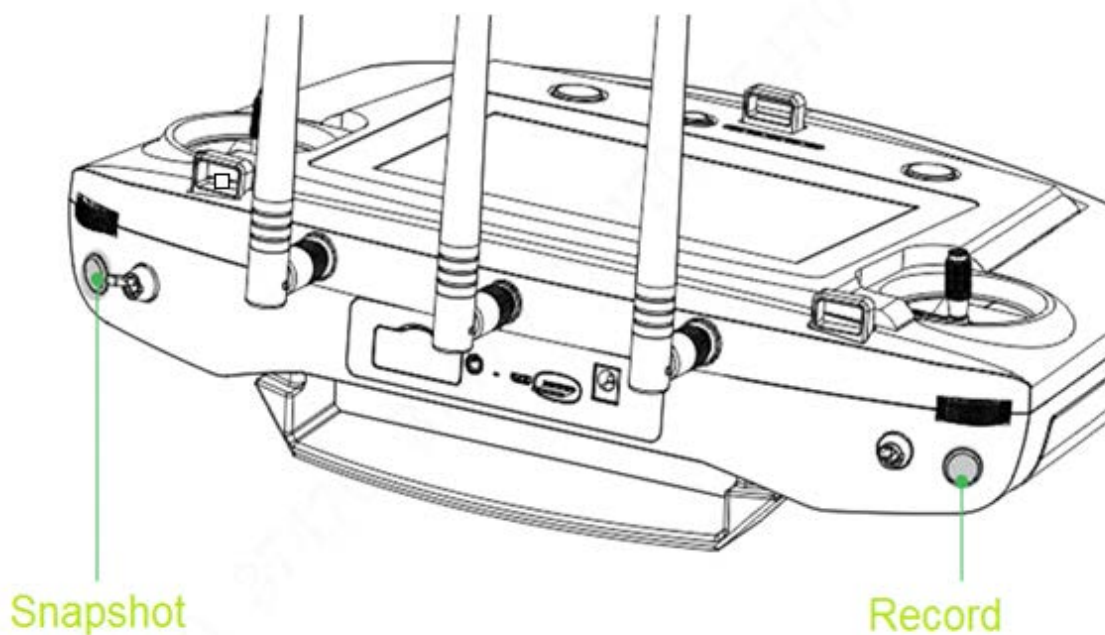

Figure 2-15



- Snapshot: Press snapshot button for a short time to snapshot the present image.
- Record: Press record button for a short time to begin recording video. Press it for a short time again to stop recording.

## 2.3.4 Operation Interface

After turning on with the remote control, enter main interface. It consists of the following function modules, as shown in Figure 2-16.

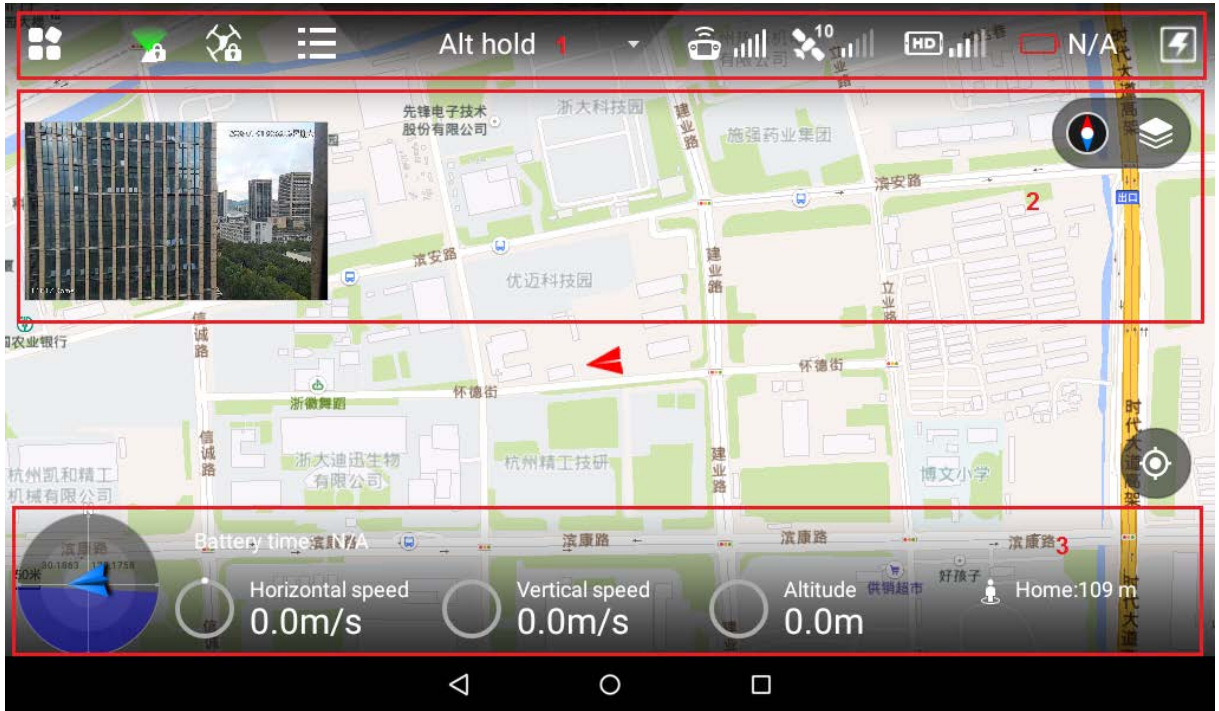

Figure 2-16



Tip

Slide up at any position on the preview interface to hide the setting menu, function bar and state bar. Slide down at any position on the main interface to view them again.

No.	Name	Function
1	Function setting and state bar	Set the menu and aircraft course; display PTZ mode, flight state list, flight mode, remote control signal intensity, GPS signal intensity, image transmission signal quality, aircraft battery and quick viewing. Please refer to “4.5 Remote Control Setting” for specific setting items and descriptions.
2	Preview window	Quickly switch video preview and map preview to display prompt information and PTZ control. Please refer to “2.3.4.3 Preview” for details.
3	State bar	Display remaining flight time, aircraft speed, height and distance from the HOME. Please refer to “2.3.4.2 State Display Bar” for details.

Table 2-6

### 2.3.4.1 Function Setting and State Bar



Figure 2-17

Icon	Name	Function
	Settings	Click this icon to enter setting menu. Please refer to “2.3.4.1.1 Setting” for details.
	PTZ mode	Display present PTZ mode (PTZ locking or PTZ following mode). <ul style="list-style-type: none"> <li>: When the PTZ lever is at the lower level, the PTZ camera has locked the course direction. No matter how aircraft angle changes, the PTZ camera is still facing the same direction to shoot.</li> <li>: When the PTZ lever is at the upper level, the PTZ camera direction is flight following mode. The shooting angle changes with the aircraft course angle.</li> </ul>
	Locking mode	Click this icon to set aircraft course locking or return locking mode. Please refer to “2.3.4.1.2 Locking Mode” for details.
	Drone state list	Click this icon, and aircraft state list will pop up. View compass, accelerometer, gyro, remote mode, GPS signal, drone battery and camera SD card remaining/total capacity info.
	Flight mode display	Display present flight mode of the aircraft, including intelligent flight, loiter and fixed point mode.
	Remote control signal intensity	Display signal intensity of remote control and aircraft. There are max. 5 bars. The more the highlighted bar amount is, the stronger the remote control effect is.
	GPS satellite and signal intensity	<ul style="list-style-type: none"> <li>The number on the left side is the GPS satellite amount.</li> <li>The GPS signal intensity is shown on the right. There are max. 5 bars. The more the highlighted bar amount is, the stronger the remote control effect is.</li> </ul>
	Image transmission signal quality	Click this icon, and image transmission signal quality frame will pop up. Display general signal quality of image transmission antenna.
	Remaining battery of aircraft	Display battery info of the aircraft. Display N/A when the aircraft is not connected; display present aircraft battery percentage after



Icon	Name	Function
		pairing connection.
	Quick operation	Click this icon to enter quick entry interface, and set dashboard, PTZ, image transfer and other quick options. Please refer to “3.6.5 Set Quick Operation” for details.

Table 2-7

### 2.3.4.1.1 Setting

Click  to enter setting interface, as shown in Table 2-8.

Level 1 Menu	Level 2 Menu	Level 3 Menu	Function
Remote Control	Control joystick mode	-	Provide two modes. Please refer to “4.2.4 Manual Flight Control” for details.
	Remote control calibration	-	Calibrate the remote control. Please refer to “3.8.1 Remote Control Calibration” for details.
	Remote pair	-	Pair the remote control and aircraft again. Please refer to “Appendix 3 System Pairing” for details.
	Remote button user-defined	-	Indicate A1 button and function of the remote control. Please refer to “4.5.1 Remote Button User-defined” for details.
Flight	Fence enable	-	Enable or disable e-fence. Please refer to “4.5.2.2 Enable Electronic Fence” for details.
	Fence settings	Fence type	Set e-fence type. Please refer to “4.5.2.1.1 Fence Type” for details.
		Fence action	Select fence action. Please refer to “4.5.2.1.2 Fence Action” for details.
		Max height	Set max. height, max. radius and reach distance of the fence. Please refer to “4.5.2.1.3 Other Settings” for details.
		Max radius	
		Reach distance	
Preview	Image transmission settings	-	Set preview image size. Please refer to “4.5.3 Preview Settings” for details.
Camera	Photo settings	-	Set photo size. Please refer to “4.5.4.1 Photo Settings” for details.



Level 1 Menu	Level 2 Menu	Level 3 Menu	Function	
	Video settings	-	Set relevant parameters of video. Please refer to “4.5.4.2 Video Settings” for details.	
	Advanced	Image settings	Set brightness, contrast, saturation, sharpness and gamma value. Please refer to “4.5.4.3 Image Settings” for details.	
General	Aircraft firmware upgrade	-	Check firmware status and upgrade. Please refer to “6.1 Firmware Update” for details.	
	APP upgrade	-	Check APP status and upgrade. Please refer to “6.2.1 APP Update” for details.	
	Other	Geomagnetic calibration	Geomagnetic calibration	Calibrate geomagnetism. Please refer to “3.8.4 Geomagnetic Abnormity” for details.
		Accelerometer calibration	Accelerometer calibration	Calibrate accelerometer. Please refer to “3.8.2 Accelerometer Calibration” for details.
		Offline map	Offline map	Add or delete offline map. Please refer to “6.2.2 Download and Update Offline Map of Remote Control” for details.
		Brightness	Brightness	Adjust brightness of tablet PC. Please refer to “4.5.5.1.3 Brightness” for details.
		Date and time	Date and time	Set the date and time of remote control. Please refer to “4.5.5.1.4 Date and time” for details.
		Network setting	Network setting	Set networking mode. Please refer to “4.5.5.1.1 Network Settings” for details.
		Language	Language	Set software language of remote control. Please refer to “4.5.5.1.5 Language” for details.
	Storage setting	Storage setting	View total storage space of Micro SD card and the space occupied by every part. Please refer to “4.5.5.1.2 Micro SD Settings” for details.	
About	Hardware version	Hardware version	Display hardware info.	

Table 2-8

On settings interface, click  to return to the previous menu and click  to exit settings.

### 2.3.4.1.2 Locking Mode

Click it to select locking mode of the aircraft on the popped up dialog box, as shown in Figure 2-18.



Figure 2-18

### 2.3.4.1.3 Flight State List

Click the icon to display drone state list, as shown in Figure 2-19.

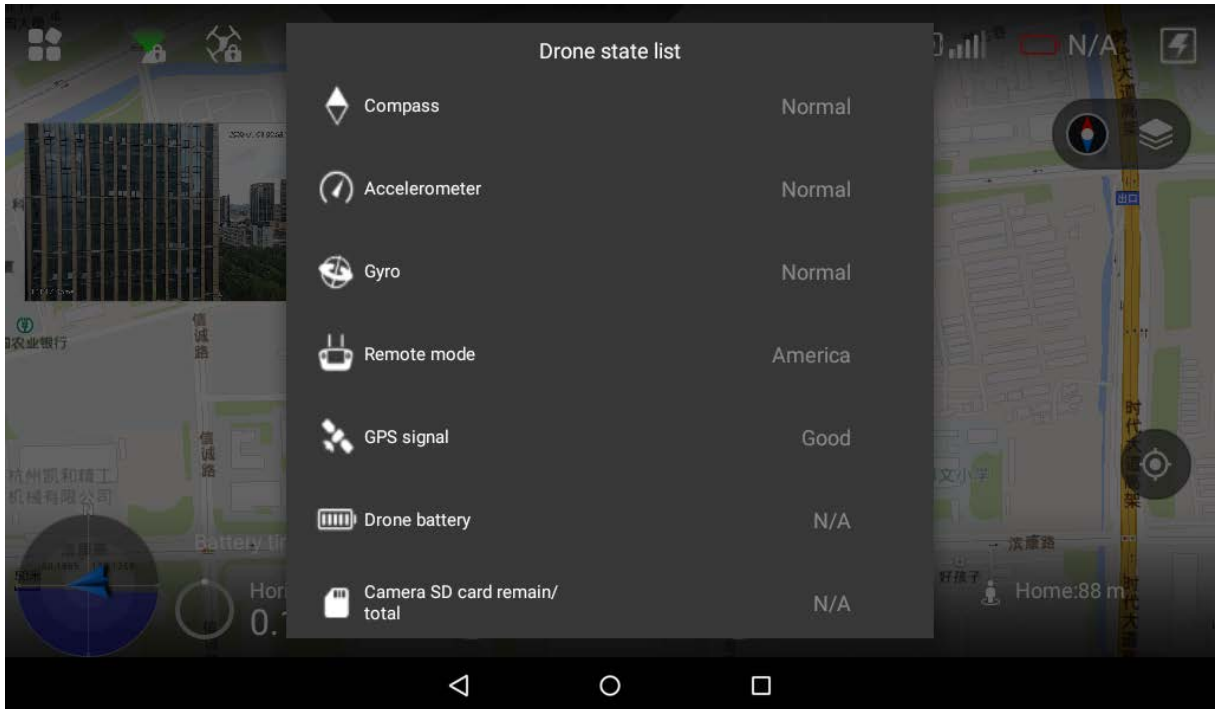

Figure 2-19

View drone state info in a real-time way.

### 2.3.4.1.4 Quick Operation

Realize quick setting of dashboard, PTZ, image transfer and others. Please refer to "3.6.5 Set Quick Operation" for details.

Click the icon to display quick operation, as shown in Figure 2-20.

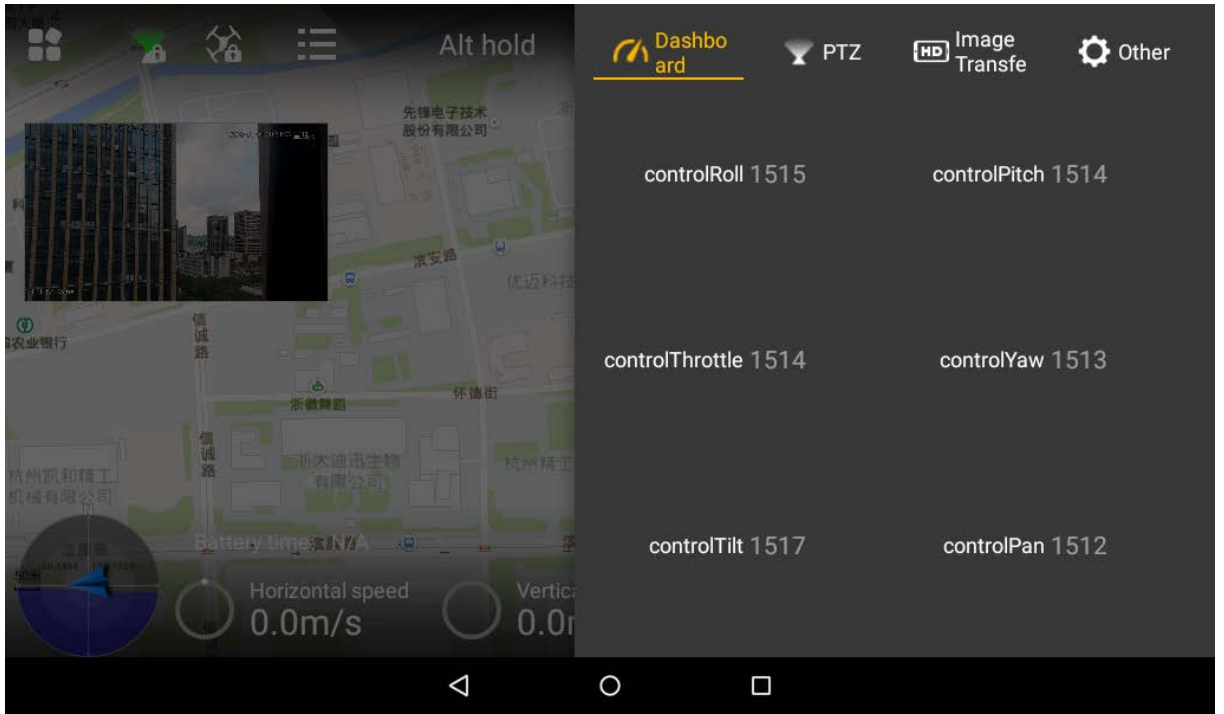

Figure 2-20

### 2.3.4.2 State Display Bar

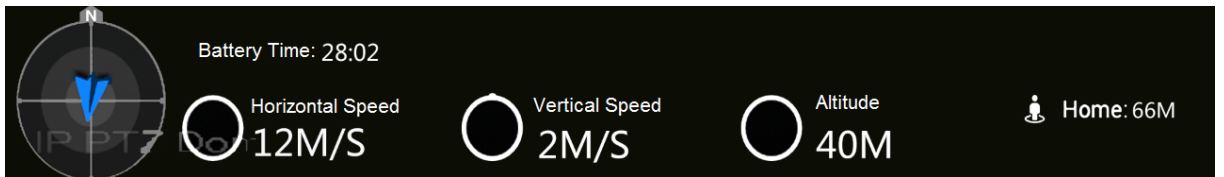

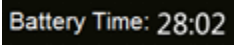



Figure 2-21

Icon	Name	Function
	Aircraft direction and camera lens direction	Blue triangle: it indicates the aircraft direction on the geographic position.
	Battery time	<p>Display remaining flight time of the aircraft. It displays N/A when the aircraft is not connected.</p> <p> <b>Note</b></p> <p>This estimated value is for reference only. Actual flight time may be affected by enviroment and etc., so it may be different from the actual flight time.</p>

Icon	Name	Function
	Horizontal speed	Horizontal forward and backward speed of the aircraft. It displays N/A when the aircraft is not connected.
	Vertical speed	Vertical ascending and descending speed of the aircraft. It displays N/A when the aircraft is not connected.
	Altitude	Relative altitude from the takeoff position. It displays N/A when the aircraft is not connected.
	Distance from the HOME	Distance between the aircraft and Home. This value is planar projection distance.

Table 2-9

### 2.3.4.3 Preview

Click the window at the top left corner, to switch between video preview mode and map preview mode.



Prompt information is displayed on the right side of the icon. Click the icon to view message list.

#### 2.3.4.3.1 Video Preview Mode

Default preview mode is shown in Figure 2-22.

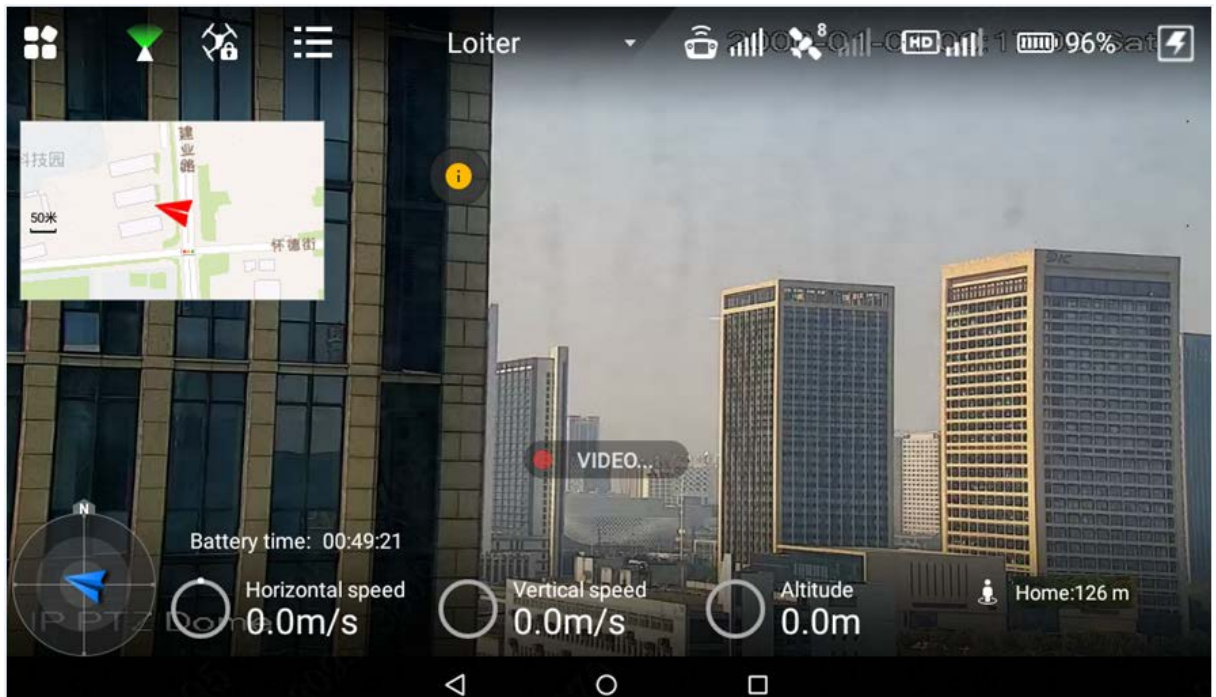

Figure 2-22

- In this mode, the map is displayed in a small window at the top left corner of the preview interface.
- In this mode, the large window displays the real-time image transmitted by the camera to the remote control.

### 2.3.4.3.2 Map Preview Mode

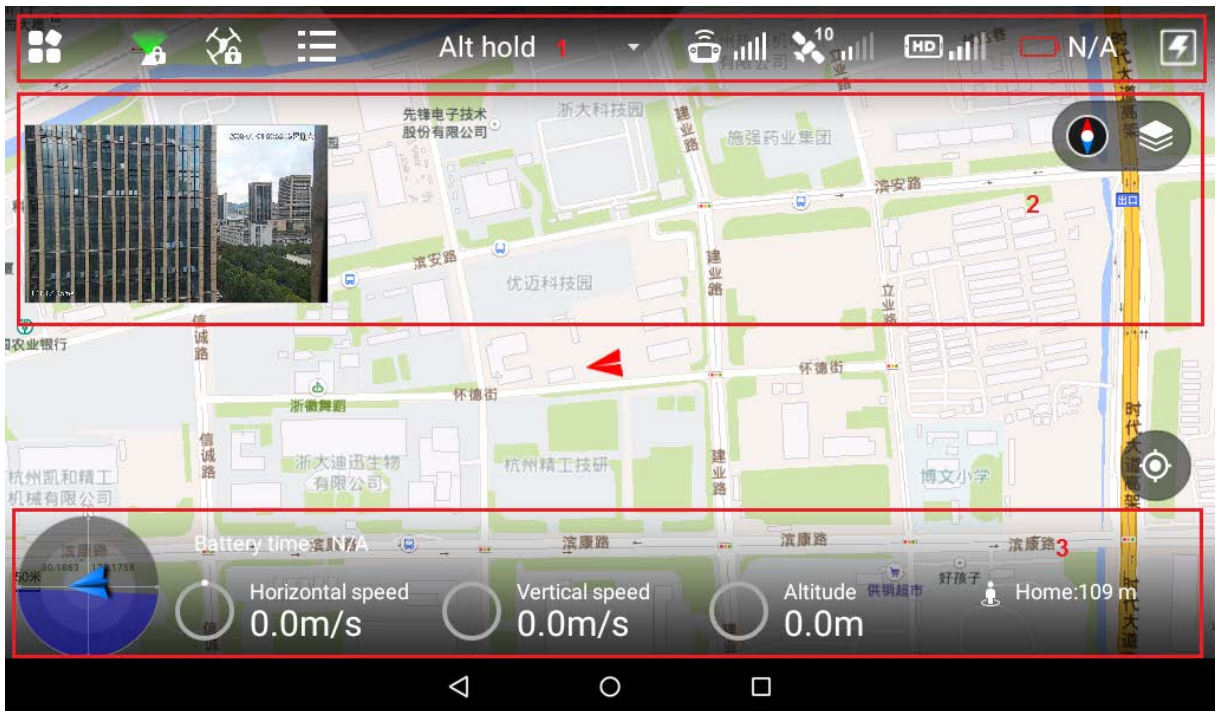





Figure 2-23

- In this mode, the image transmitted by the camera to the remote control is displayed in a small window at the top left corner of the preview interface.
- In this mode, the large window displays aircraft position on the map.

Buttons in map preview mode are described as follows:

-  Map direction locking button: When it is unlocked, press the map interface with two fingers to rotate the map; when it is locked, map direction cannot be changed.
-  Map display mode switching button: Switch to display the map in the form of satellite imagery or 2D image.
-  Central button: Switch to current position of the aircraft quickly and center at current position of the aircraft.

### 2.3.4.4 General Functions

#### 2.3.4.4.1 Set Home Point

Click the icon to set current location of the aircraft to be Home, as shown in Figure 2-24.



Figure 2-24

#### 2.3.4.4.2 Locking Mode

Click the icon to select locking mode of the aircraft on the popped up dialog box, as shown in Figure 2-25.



Figure 2-25

# 3 Flight Preparation

## Note

- This chapter elaborates complete flow before the aircraft is unlocked and takes off.
- Please select operation according to the actual situation after the first flight is over, if it is not the used for the first time.

## Caution

Please operate by strictly conforming to the steps described in this chapter; the operation sequence can't be reversed.

Flight  
Preparation  
Phase

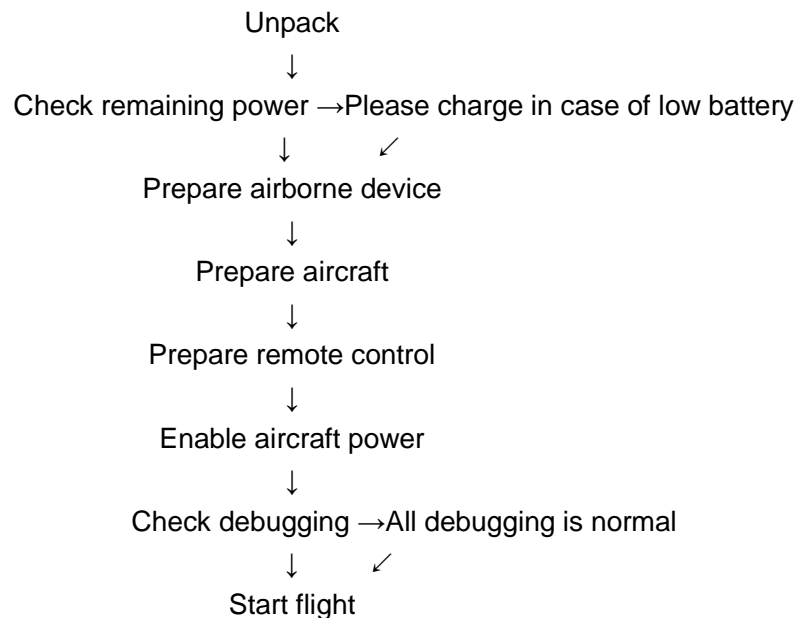

Figure 3-1

## 3.1 Unpack

Take out aircraft, battery, propellers and remote control from the packing box.

## 3.2 Check Remaining Power

Check the remaining power of aircraft battery and remote control. Implement the subsequent steps after confirming that the battery reaches the standard.

Please refer to “3.3 Charging” when the battery is low. Please implement the subsequent steps after charging.

## 3.2.1 Aircraft

### 3.2.1.1 Aircraft Battery Check

Short press the aircraft battery switch and check the state of indicator lights, as shown in Figure 3-2.

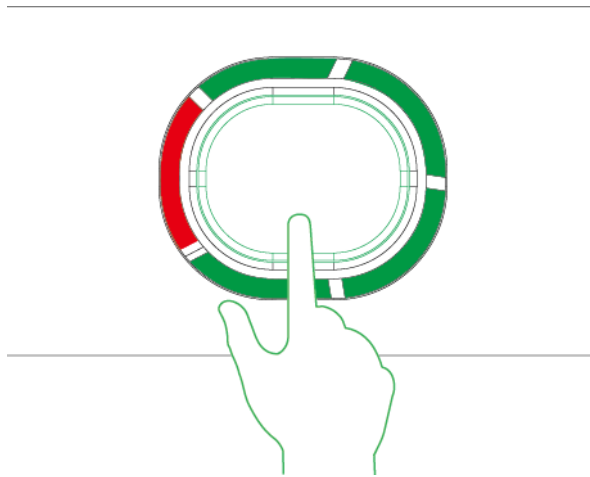

Figure 3-2

Battery switch has 5 indicator light states. The front red indicator light means that the battery is on, whereas the other 4 green indicator lights represent remaining power of the battery.

- At normal temperature, the remaining power shall be  $\geq 2$ .
- The aircraft shall take off with full power when temperature is lower than  $-10^{\circ}\text{C}$ .

### 3.2.1.2 Aircraft Remaining Power

There are three states for each indicator light of the aircraft battery, which are normally on, flash and off.

The following table describes remaining power percentage in different status. “●” means normally on, “◎” means flash and “○” means off, as shown in Table 3-1.

No.	Indicator Light Status	Remaining Battery Percentage Range
1	●●●●~●●●◎	100%~87.5%
2	●●●◎~●●●○	87.5%~75%
3	●●●○~●●◎○	75%~62.5%
4	●●◎○~●●○○	62.5%~50%
5	●●○○~●◎○○	50%~37.5%
6	●◎○○~●○○○	37.5%~25%
7	●○○○~◎○○○	25%~12.5%
8	◎○○○~○○○○	12.5%~0

Table 3-1



## 3.2.2 Remote Control

### 3.2.2.1 Remote Control Battery Check

Move the power switch to the arrow location; view the number of indicator lights which are on.



Figure 3-3

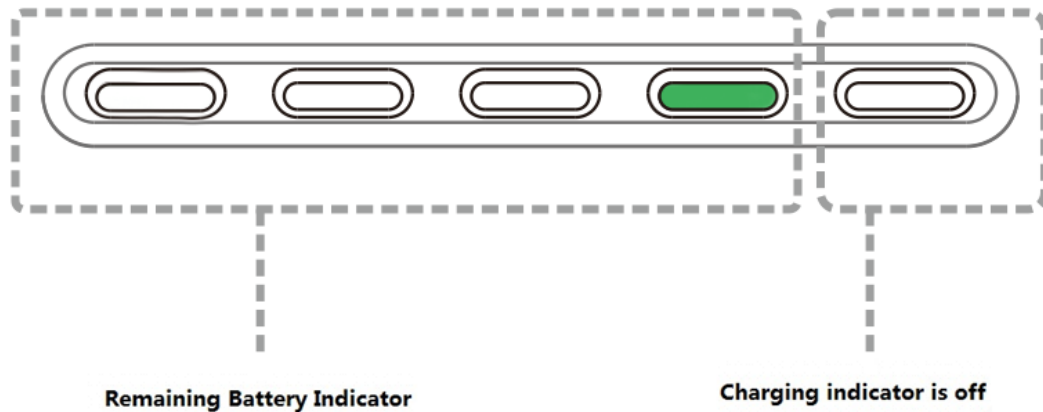

Figure 3-4

- At normal temperature, the remaining power shall be  $\geq 2$ .
- Remaining power shall be  $\geq 3$  when the temperature is lower than  $-10^{\circ}\text{C}$ .

### 3.2.2.2 Remaining Power of Remote Control

There are two statuses for each indicator light of remote control, which are normally on and off.

The following table describes remaining power percentage in different status, “●” means normally on and “○” means off, as shown in Table 3-2.

No.	Indicator Light Status	Remaining Battery Percentage Range
1	●●●●~○●●●	100%~75%
2	○●●●~○○●●	75%~50%
3	○○●●~○○○●	50%~25%
4	○○○●~○○○○	25%~0

Table 3-2

## 3.3 Charging



It doesn't need to implement the following chapter if the remaining power is enough.

### 3.3.1 Aircraft Battery Charging



During charging of power battery, charging is completed when the charger displays “FULL” and beeps. Don't take down batteries before charging is completed.

The entire charging period (from 0 to full) is about 2 hours. Charging period is related with remaining power and charging current.

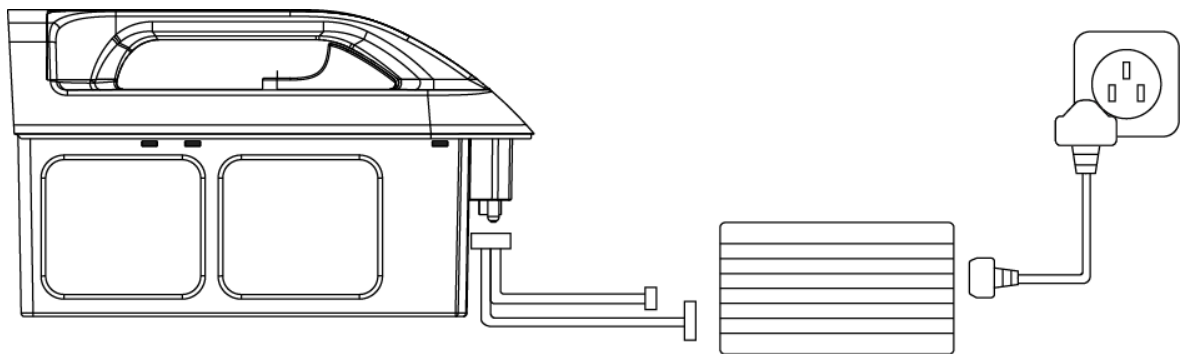

Figure 3-5

- Step 1 Take out the battery: open battery switch, and lift the battery vertically to take it out.
- Step 2 Connect AC: connect charger power wire with charger port, and connect AC power.
- Step 3 Connect DC: insert charging adapter cable into battery and charger port.
- Step 4 Select charging mode: open charger switch, turn the black button, select BLC and short press the black button. The value displayed by LED nixie tube bounces and flashes.
- Step 5 Select charging current: turn the button to adjust current, whose proposed value is 20A. After adjustment, short press the black button to confirm.
- Step 6 Open the battery: short press the battery indicator light button once, and then long press it for 3 seconds, to turn on the electric quantity indicator light and check present battery.
- Step 7 Long press the button to start charging and wait for the charger prompt. It means charging is completed when the charger beeps for 5 times and LED nixie tube displays FULL.

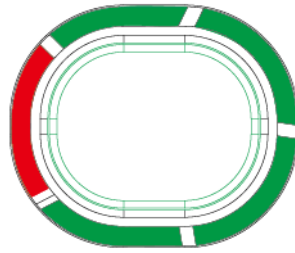

Figure 3-6

Step 8 After charging is completed, disconnect it from the power socket, and then press stop button on the charger to turn off the charger.

### 3.3.2 Remote Control Charging

The entire charging period (from 0 to full) needs approximately 3.5 hours.

Please charge the remote control when its power is off.

Step 1 Connect DC: connect the remote control and power adapter with a charging cable.

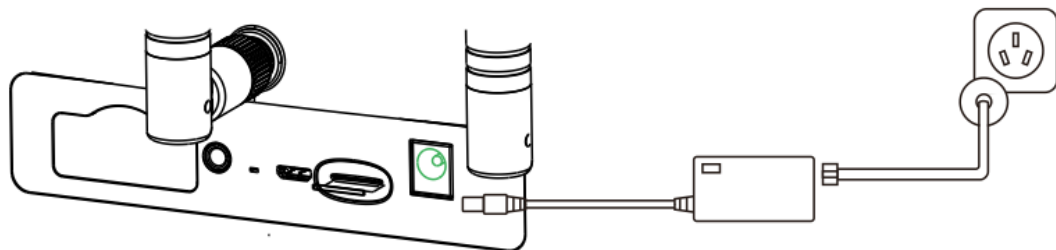

Figure 3-7

Step 2 Connect AC: connect power adapter with AC power (AC 100V- AC 240V).

Step 3 Check charging state: it means the remote control is charging when the indicator light is red and normally on. It means charging is done when the indicator light becomes green and normally on, as shown in Figure 3-8.



Figure 3-8

Step 4 Disconnect it from the power socket, and then disconnect other cables after charging is completed.

## 3.4 Prepare Airborne Device

### Note

- The following chapter is optional for operation. It is for your reference when airborne device shall be replaced.
- This chapter introduces operation of airborne device with PTZ camera as an example.

Please refer to actual product.

- Please implement demounting step first and then connection step when the PTZ camera needs to be replaced.
- It only needs to implement demounting step when the aircraft flies directly without PTZ camera.

### 3.4.1 Demount PTZ Camera

Step 1 Loosen 4 mounting screws, as shown in Figure 3-9.

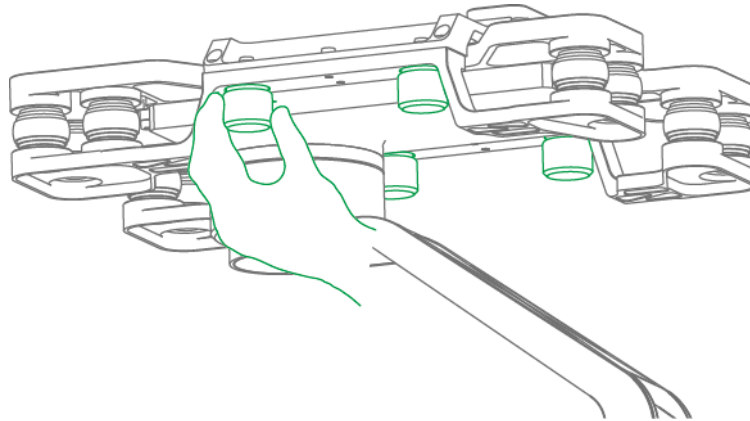

Figure 3-9

Step 2 Take down PTZ camera.

### 3.4.2 Install PTZ Camera

Step 1 Insert the upper port on the vibration damper plate of the PTZ camera into corresponding port at the bottom of the aircraft, as shown in Figure 3-10.

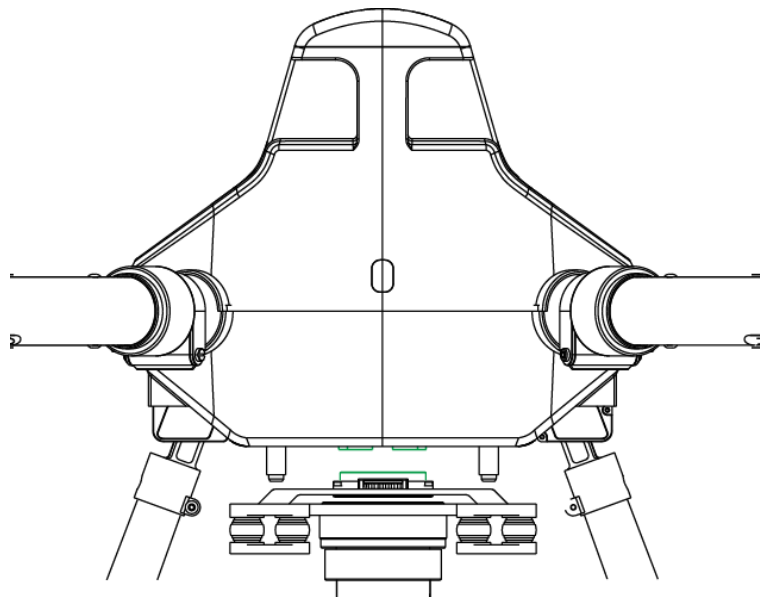

Figure 3-10

Step 2 Align 4 mounting screws with the hole positions at the bottom of the aircraft, and tighten the screws.

## 3.5 Prepare Aircraft

### 3.5.1 Unfold Arm

Unfold the arm to horizontal position. Hold the arm with left hand, and tighten helical casing with right hand, so as to fix the arm horizontally, as shown in Figure 3-11.



Caution

The subsequent steps can be implemented only when the arm is fixed horizontally. Please contact our company if the arm is loose.

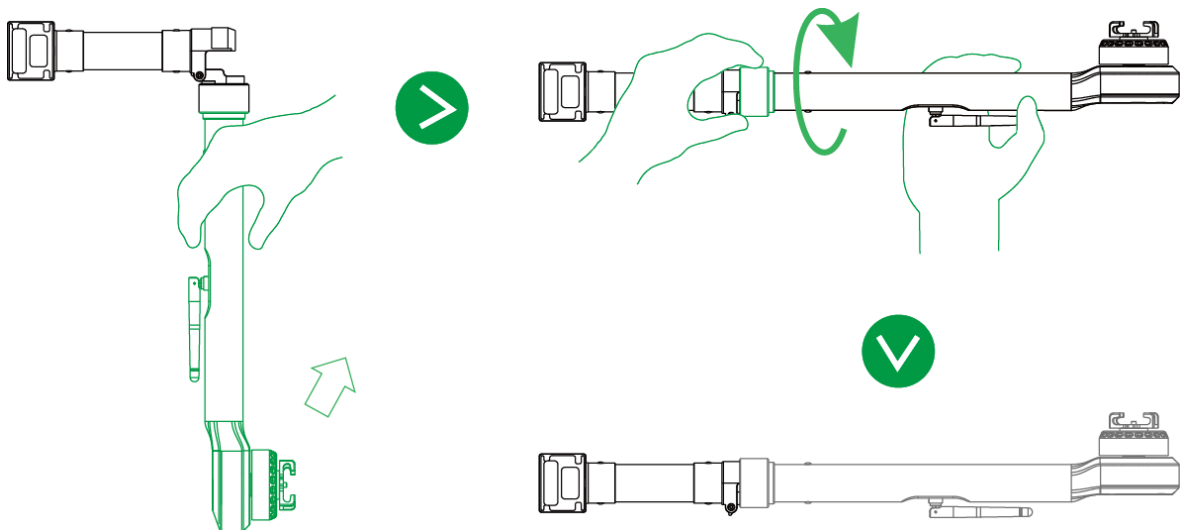

Figure 3-11

### 3.5.2 Open Antenna



Tips

It is recommended to unfold the antenna to vertical position, in order to realize optimum communication effect.

Unfold the aircraft antenna, move it to vertical position and make it firmly stuck, as shown in Figure 3-12.

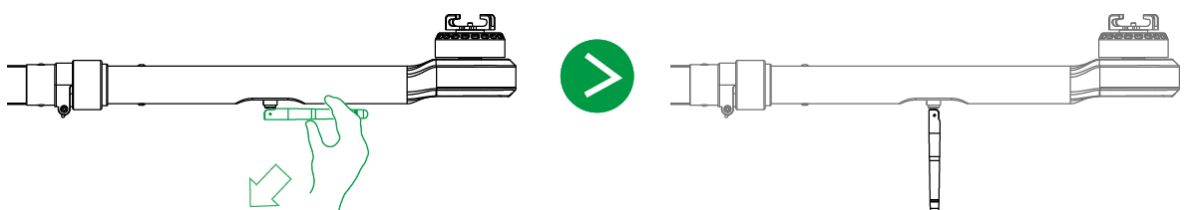

Figure 3-12

### 3.5.3 Install Aircraft Battery

#### Caution

- After battery has been installed, battery buckle shall be fixed. Then, the aircraft can be moved with battery handle.
- If battery buckle is not fixed, the aircraft will fall off.

Step 1 Open the battery buckle, as shown in Figure 3-13.

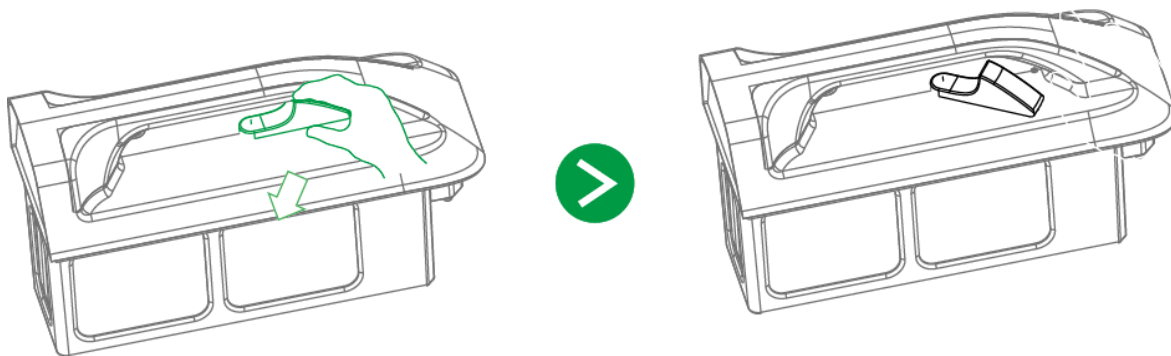

Figure 3-13

Step 2 Put the battery into battery compartment horizontally, as shown in Figure 3-14.

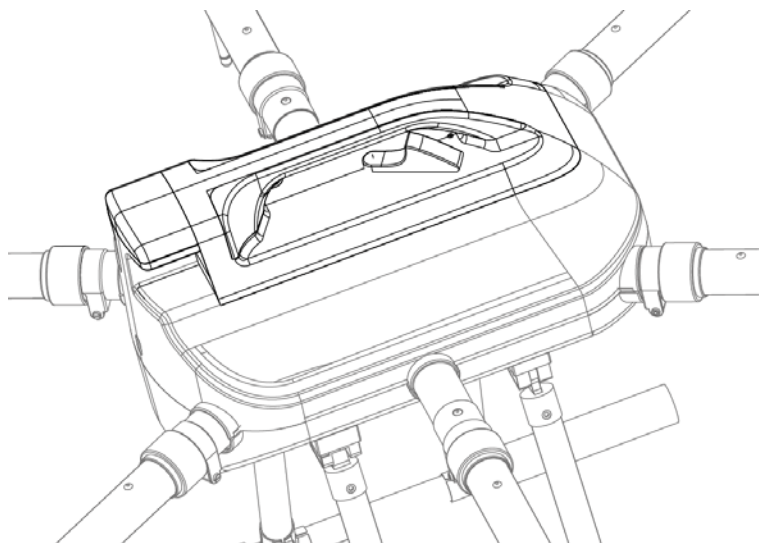

Figure 3-14

Step 3 Close the battery buckle, and aircraft battery installation has been completed.

## 3.6 Prepare Remote Control

### 3.6.1 Install Micro SD Card

Remote control owns about 3G memory space. Please choose and install micro SD Card according to actual needs.

#### Note

- The following chapter is optional for operation. It is for your reference when the user needs to install micro SD card.
- Micro SD card needs to be configured on your own.
- Micro SD card supports max. 16G.

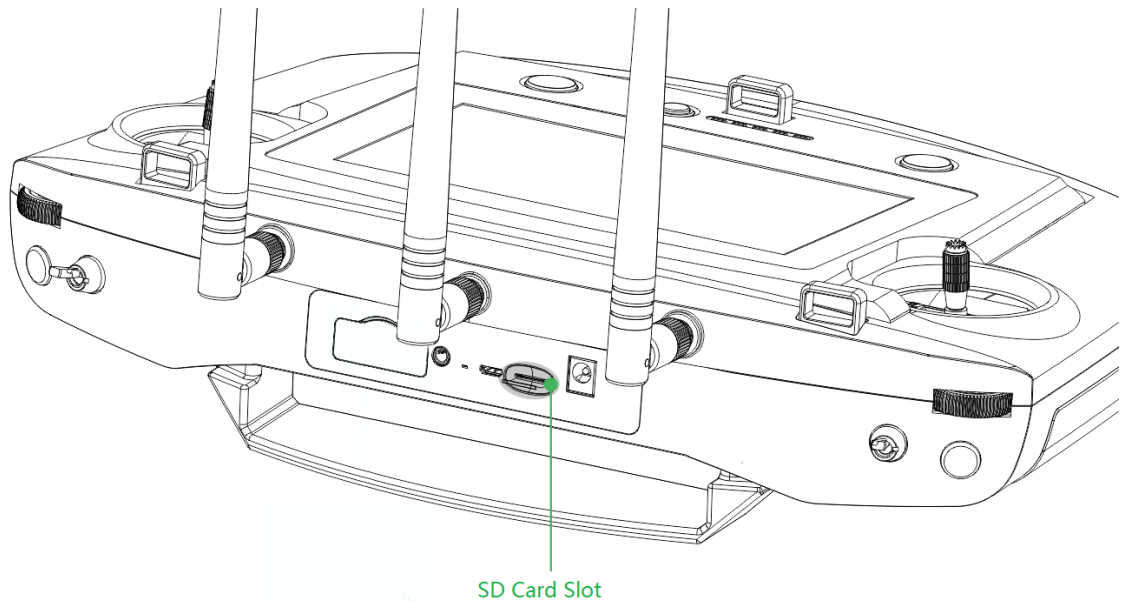

Figure 3-15

Make the metal surface of micro SD card face downward and insert it into the micro SD card slot of the remote control side panel horizontally.

### 3.6.2 Open Antenna

Open the antenna of remote control to proper location, as shown in Figure 3-16.

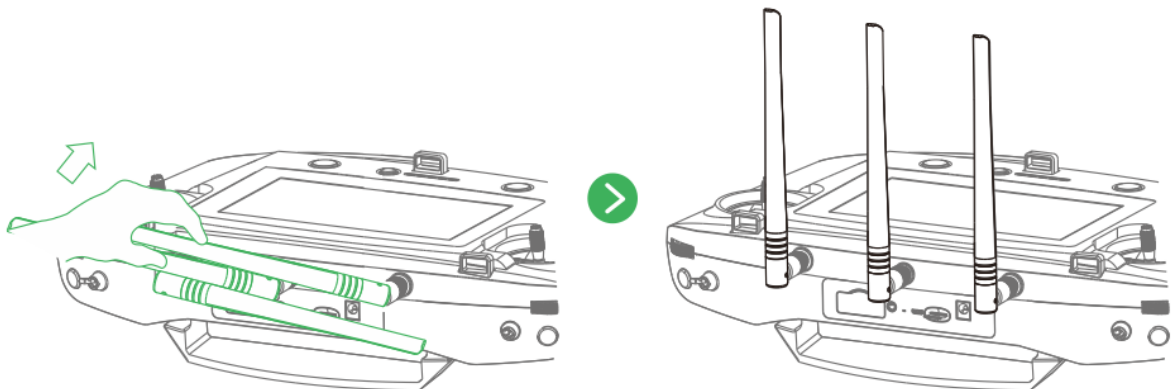

Figure 3-16

### 3.6.3 Enable Remote Control Power

#### Note

Please skip the chapter if the power is not turned off after checking remaining battery.  
 Enable remote control power: move the power button of remote control to the arrow location, as shown in Figure 3-17.



Figure 3-17

### 3.6.4 Confirm Remote Control Mode

It is mode 2 by default. Please set in “Settings > RC Settings > Joystick Mode” to switch mode, as shown in Figure 3-18.

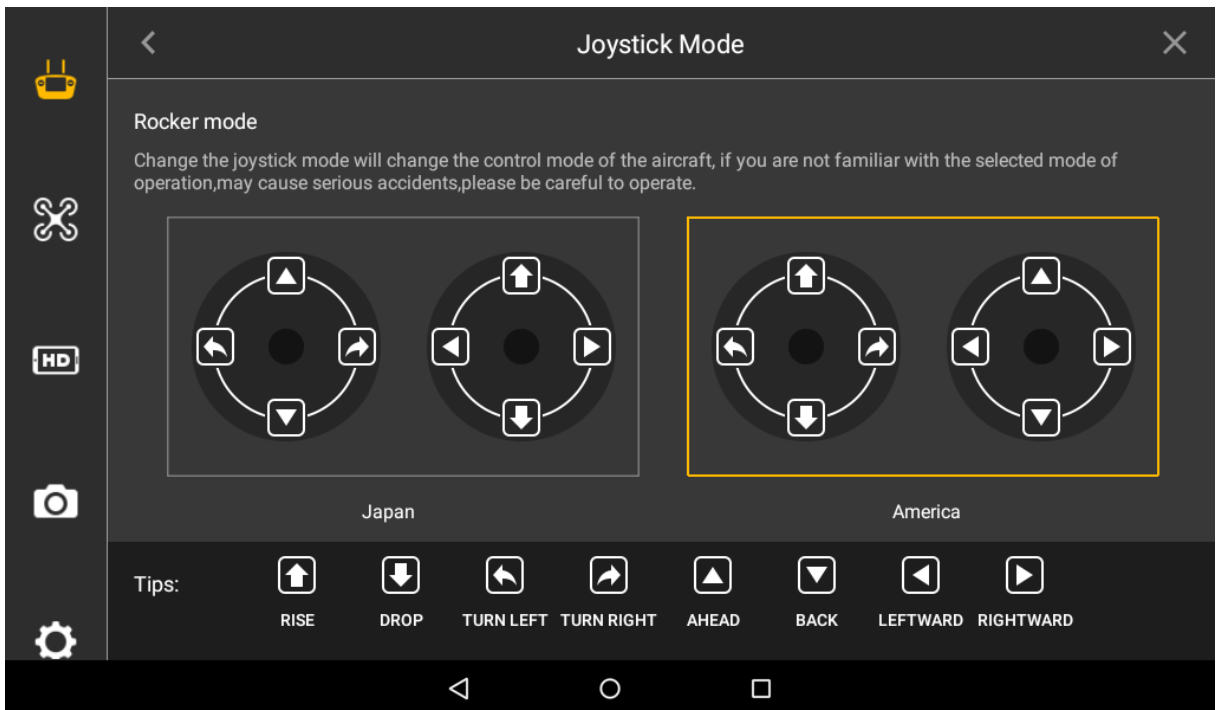



Figure 3-18

Please refer to “4.2.4 Manual Flight Control” for remote control mode and its corresponding relations.

### 3.6.5 Set Quick Operation

Click  at the upper right corner of main interface, set quick operation items of remote control interface, view dashboard, and set PTZ, image transfer, flight task, flight path and stop beep.

#### 3.6.5.1 Dashboard

View parameters of remote control dashboard.

Click “Dashboard”, and the system enters “Dashboard” interface, as shown in Figure 3-19.



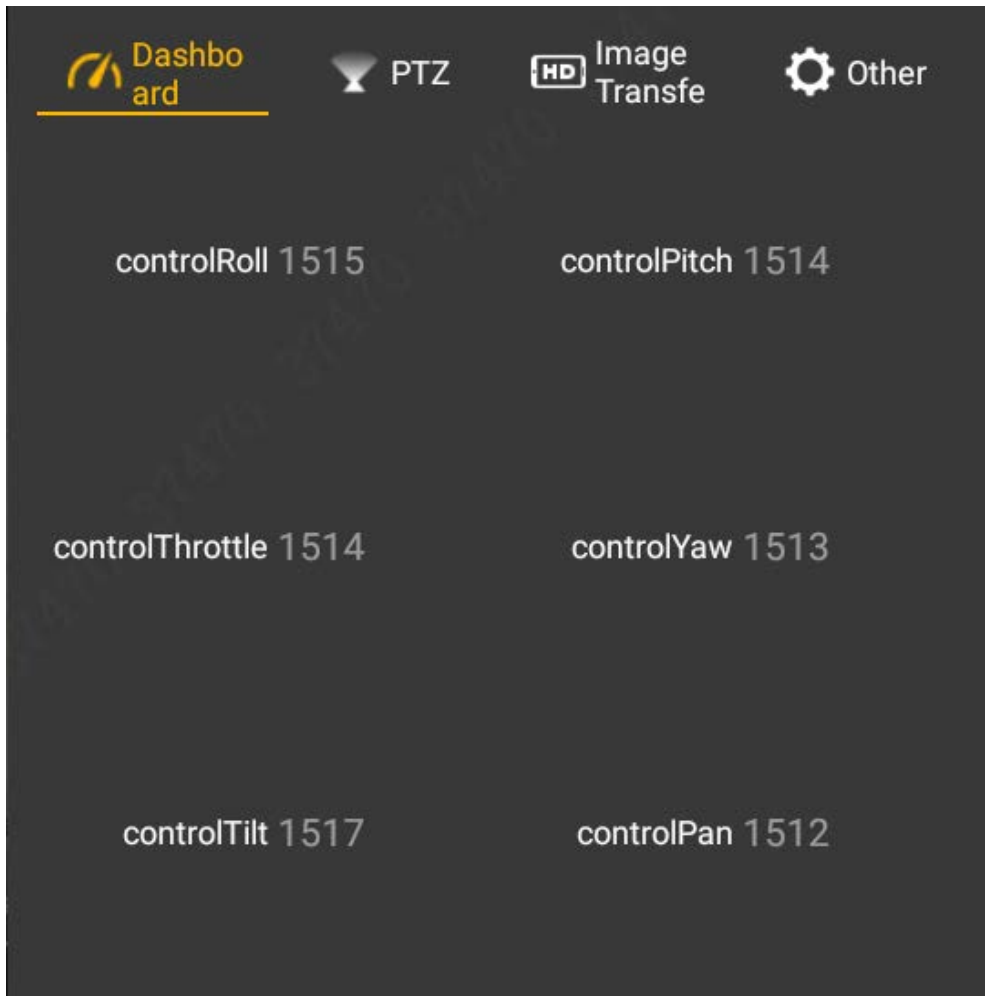

Figure 3-19

### 3.6.5.2 PTZ

Set the PTZ, such as PTZ position and throwing.

Step 1 Click "PTZ", and the system enters "PTZ" interface, as shown in Figure 3-20.

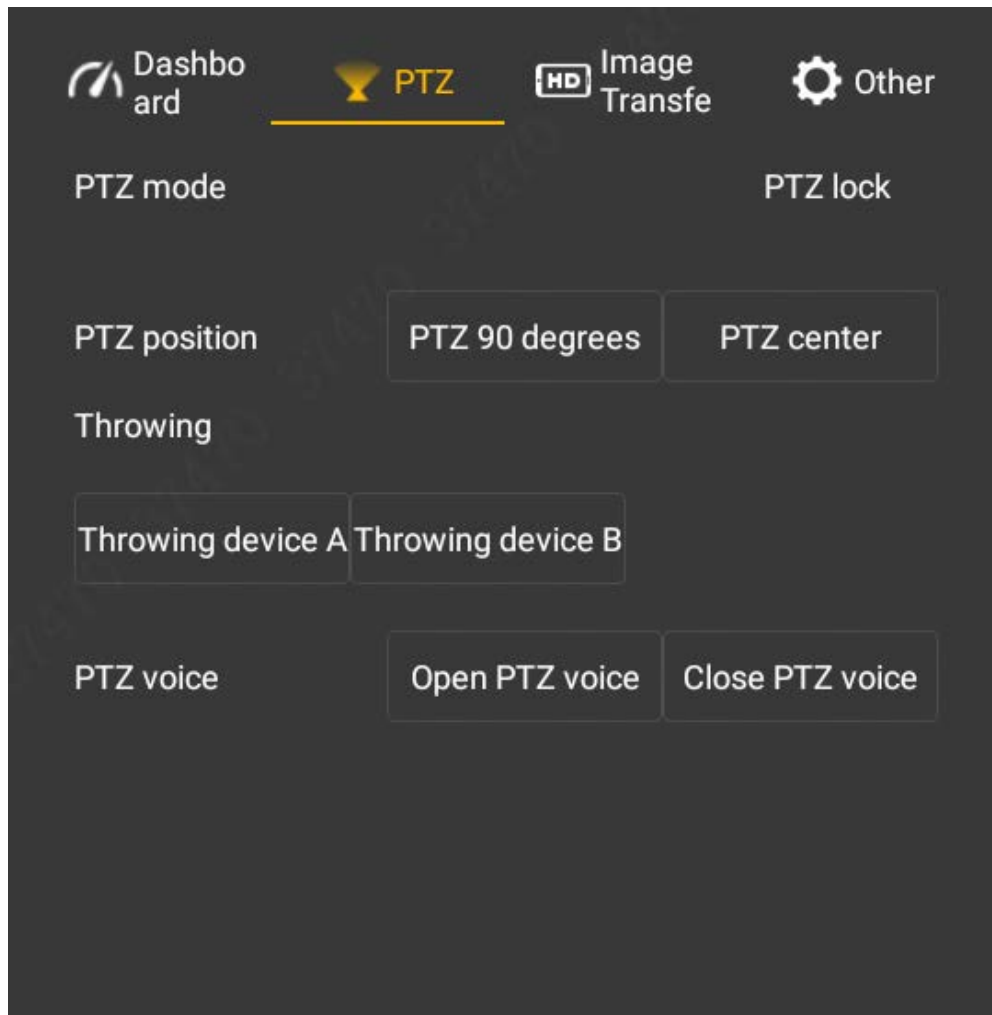

Figure 3-20

Step 2 Set parameters according to actual needs. Please refer to Table 3-3 for details.

Parameter	Note
PTZ Mode	View present mode of PTZ.
PTZ Position	Set PTZ position, including PTZ 90 degrees and PTZ center. <ul style="list-style-type: none"> <li>● PTZ 90 degrees: the camera is vertically downward.</li> <li>● PTZ center: the camera lens faces the front.</li> </ul>
Throwing	Set throwing, including throwing device A and throwing device B.

Table 3-3

 Note

Click key A on the remote control, to carry out PTZ control.

### 3.6.5.3 Image Transfer

Set resolution ratio, frame rate and maximum bandwidth of preview image according to needs.

Step 1 Select “Image Transfer”, and the system enters “Image Transfer” interface, as shown in Figure 3-21.

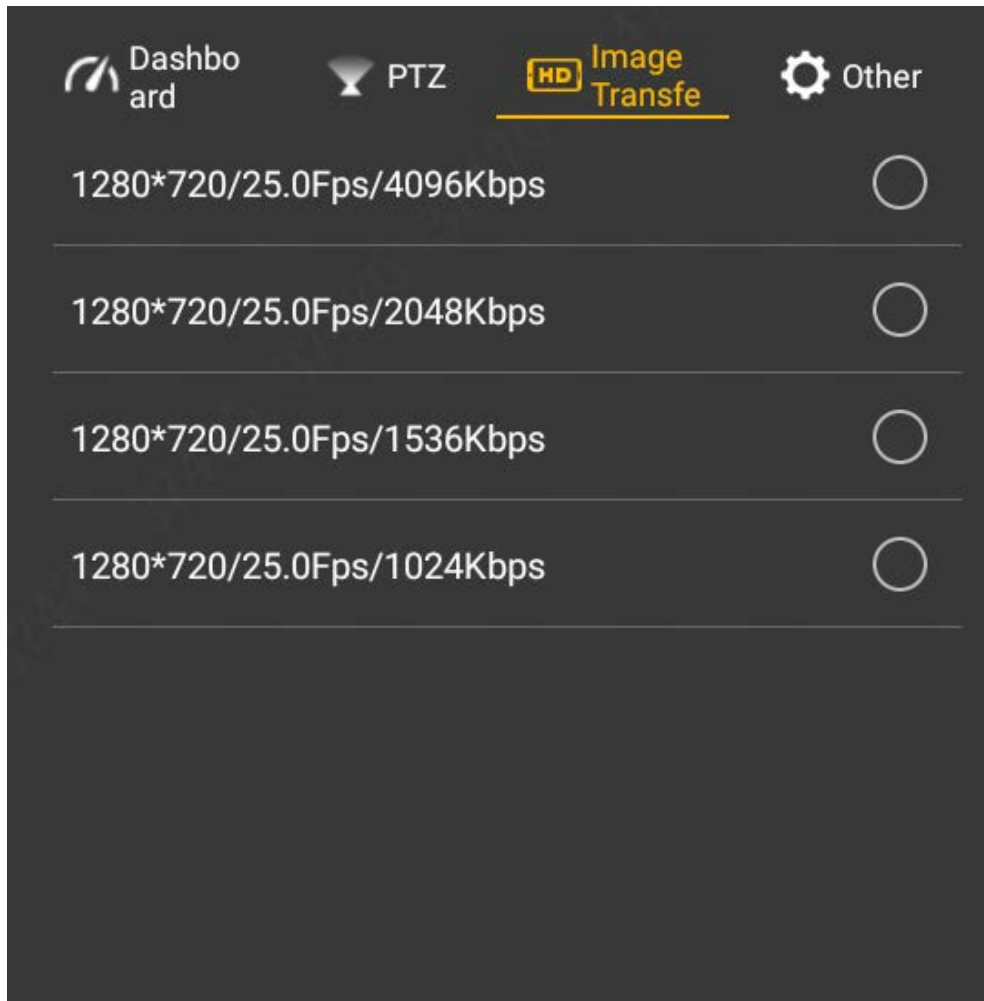

Figure 3-21

Step 2 Select resolution ratio, frame rate and maximum bandwidth of preview image according to actual needs.

### 3.6.5.4 Other

Set the flight task, flight path and stop beep here.

#### 3.6.5.4.1 Fly Task

Set the flight task of remote control according to actual needs, including flight path and flight time.

Step 1 Select "Other > Flight Task".

The system displays "Flight Task" interface, as shown in Figure 3-22.

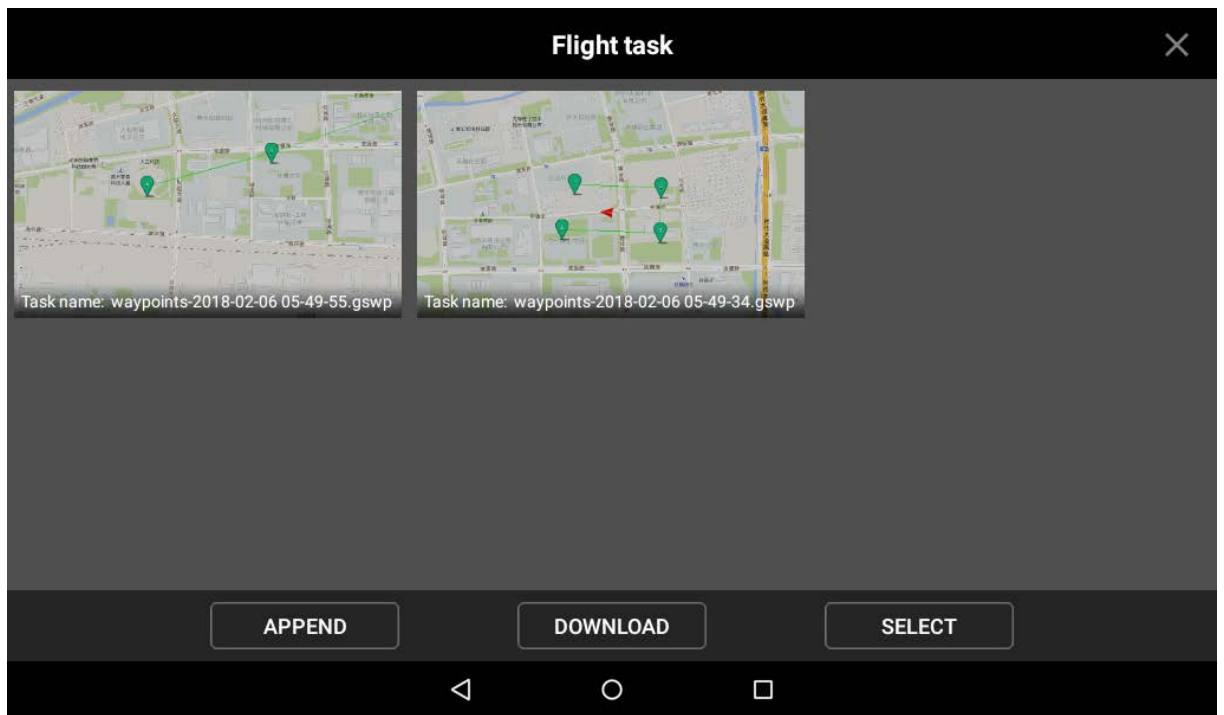

Figure 3-22

Step 2 Configure flight task according to actual needs.

- Append: click this icon to enter waypoint setting interface, set waypoint flight task according to actual needs and save it.
- Download: click this icon to download present saved flight path automatically. Modify waypoint according to actual needs and save the task at remote control.
- Select: click this icon to select one task or multiple tasks, and delete the task.

#### 3.6.5.4.2 Flight Data

Save and delete the flight path data of the aircraft.

Step 1 Select "Other > Flight Data".

The system displays "Flight Data" interface, as shown in Figure 3-23.

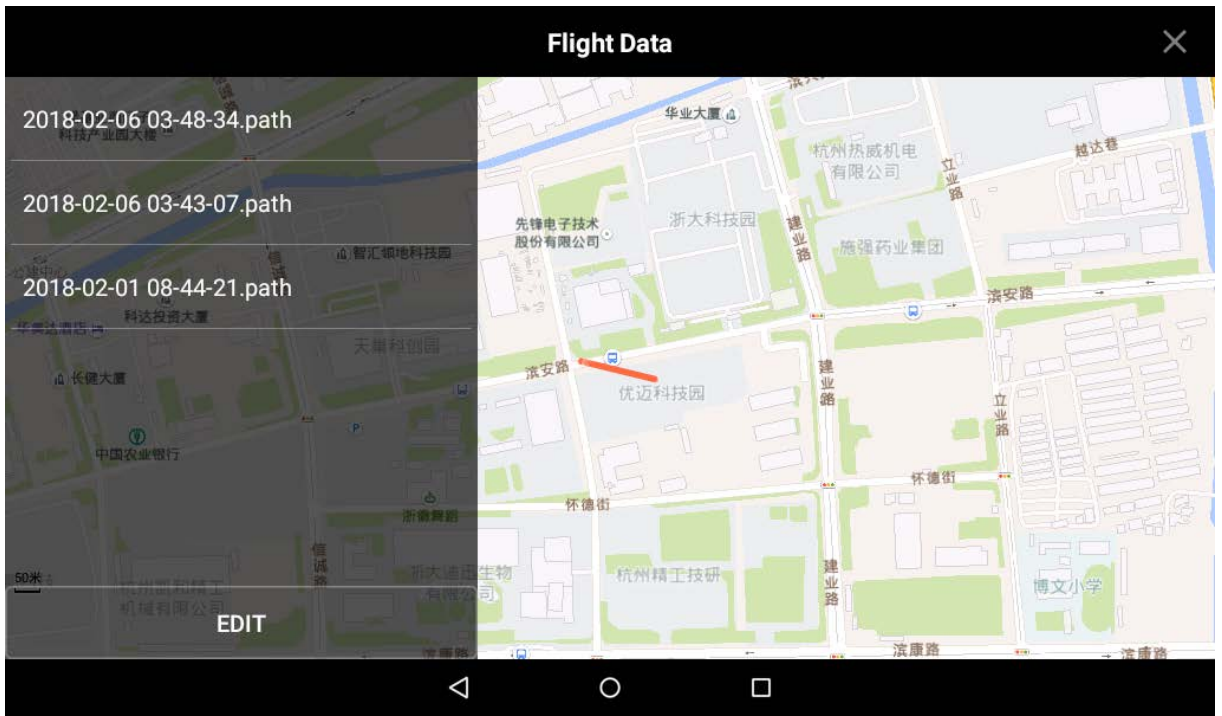

Figure 3-23

Step 2 Click "Edit".

Select the flight path which shall be deleted and saved according to actual needs, as shown in Figure 3-24.

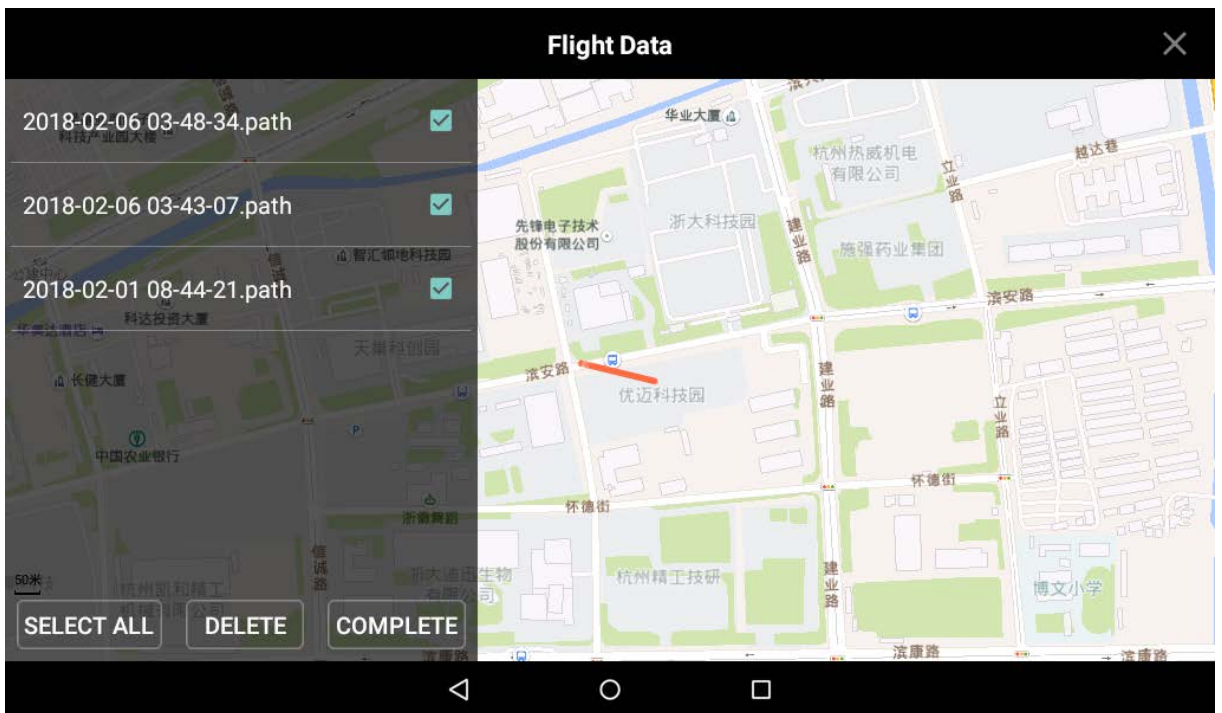

Figure 3-24

Step 3 Click "Complete" to complete flight data setting.



Click "Select All" to operate all flight data together.

## 3.7 Enable Aircraft Power

### Caution

After power on, when the remote control doesn't require other operations, please always keep the aircraft horizontal and static; otherwise, it may result in initialization failure.

### Note

The battery is full if 4 indicator lights are green.

Insert intelligent battery of the aircraft, short press power switch, and green indicator light indicates present battery electricity, as shown in Figure 3-25.

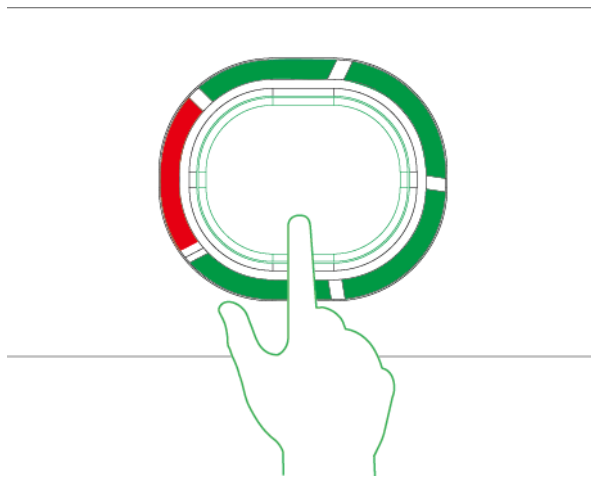

Figure 3-25

## 3.8 Check and Debugging

### Warning

The subsequent steps can be implemented only after checking and debugging all the items listed in the chapter below. Besides, the remote control prompts that each state is normal and the aircraft indicator light flashes green.

### Tips

It is recommended to set the display image of remote control as video preview mode before taking off.

Check operation condition. Please debug each component to make it operate normally when both remote control prompts abnormality.

It is going to list common calibration items, abnormalities and solutions in the following chapter.

## 3.8.1 Remote Control Calibration

### Caution

If it isn't turned to maximum value end, it may not respond to operation, operation is not smooth, and the aircraft may even explode after calibration.

Step 1 Select "Settings > Remote Control Settings> Joystick Calibration".

The system displays "Joystick Calibration" interface, as shown in Figure 3-26.

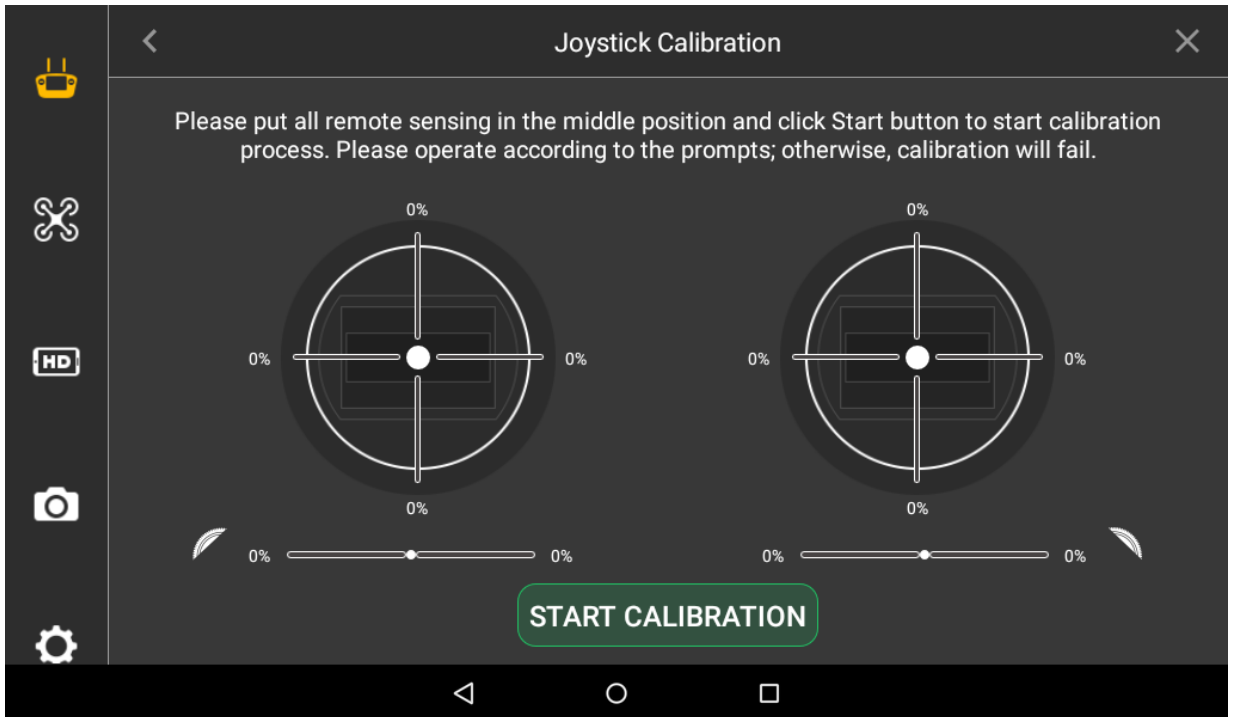

Figure 3-26

Step 2 Move both the left and right joysticks back to the middle.

Step 3 Click "Start Calibration".

Step 4 Turn two joysticks and turn to the maximum value end of each direction for several times.

Step 5 Slide the rolling wheels on both sides, slide to the maximum value end of two directions for several times.

Step 6 Click "Complete Calibration" after turning the rolling wheels and joysticks.

### Note

- After calibration, view "3.6.5.1 Dashboard", and turn corresponding buttons to confirm if calibration is successful. After successful calibration, each parameter is about 1514. Turning the endpoint, maximum value is 19XX while minimum value is 10XX.
- The remote control can be normally used about 30s after calibration.

## 3.8.2 Accelerometer Calibration

Select "Settings > General > Other > Accelerometer Calibration" to enter "Accelerometer Calibration" interface, as shown in Figure 3-27.

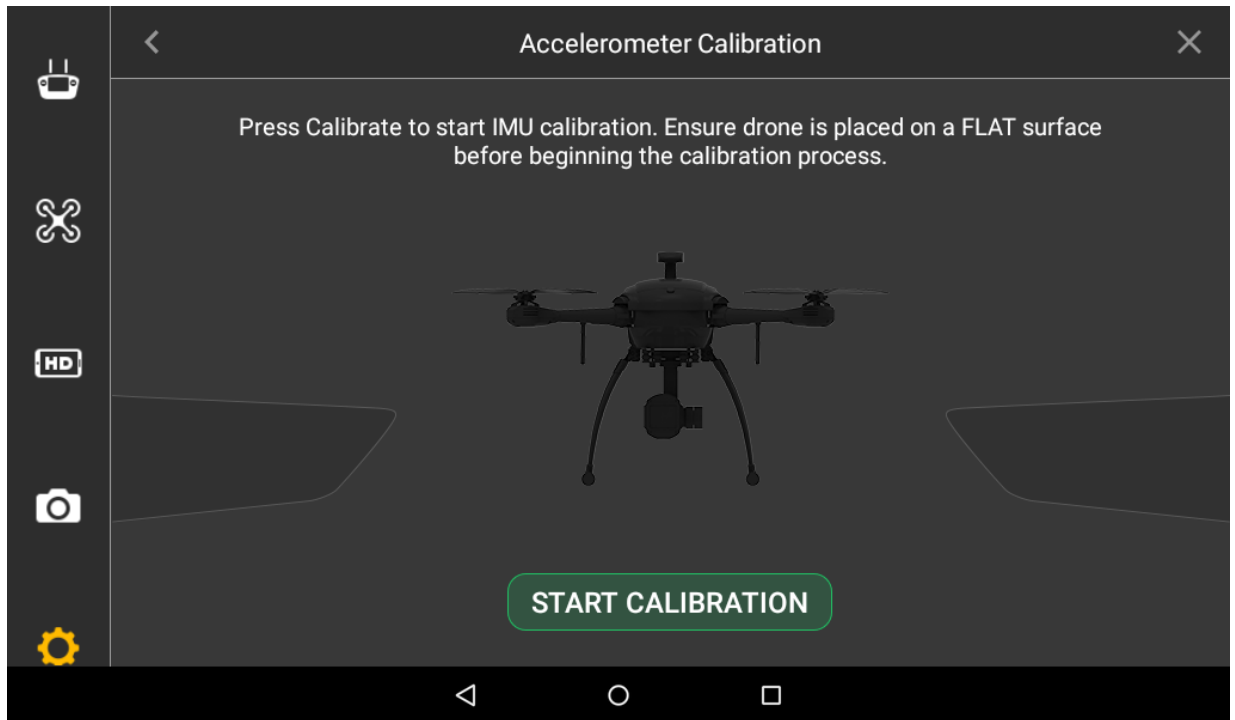

Figure 3-27

Place the aircraft on a flat surface, and click “Start Calibration”.

- The remote control will prompt “Calibration Success” if it is successfully calibrated.
- The remote control will prompt “Calibration Failure” if it fails to calibrate. Click “Retry” till it is successfully calibrated.

### Caution

Pay attention to levelness and perpendicularity during calibration. Non-standard posture during calibration will lead to abnormal flight and even explosion.

## 3.8.3 Initialization Failure

### Abnormity Prompt

Remote control prompts “Initialization Failure”.

### Possible Reasons

After power on and before taking off, it may result in initialization failure if you move the aircraft.

### Solutions

Power on the aircraft again after the power is cut off, and keep the aircraft horizontal and static during initialization. Please contact our company if initialization fails for several times.



## 3.8.4 Geomagnetic Abnormity

### Abnormity Prompt

- Aircraft indicator ●●● flashes.
- Remote control prompts “Geomagnetic Abnormity”.

### Possible Reasons

- The use position has changed a lot, which means the geographical location is quite far away from the last geographical location where the aircraft is used, causing big change to geomagnetic field.
- There is another intensive magnetic field or abrupt change in the environment, affecting geomagnetic field.

### Solutions

- Step 1 Select “Settings > General > Other > Geomagnetic Calibration” on the remote control. The system displays “Geomagnetic Calibration” interface, as shown in Figure 3-28.

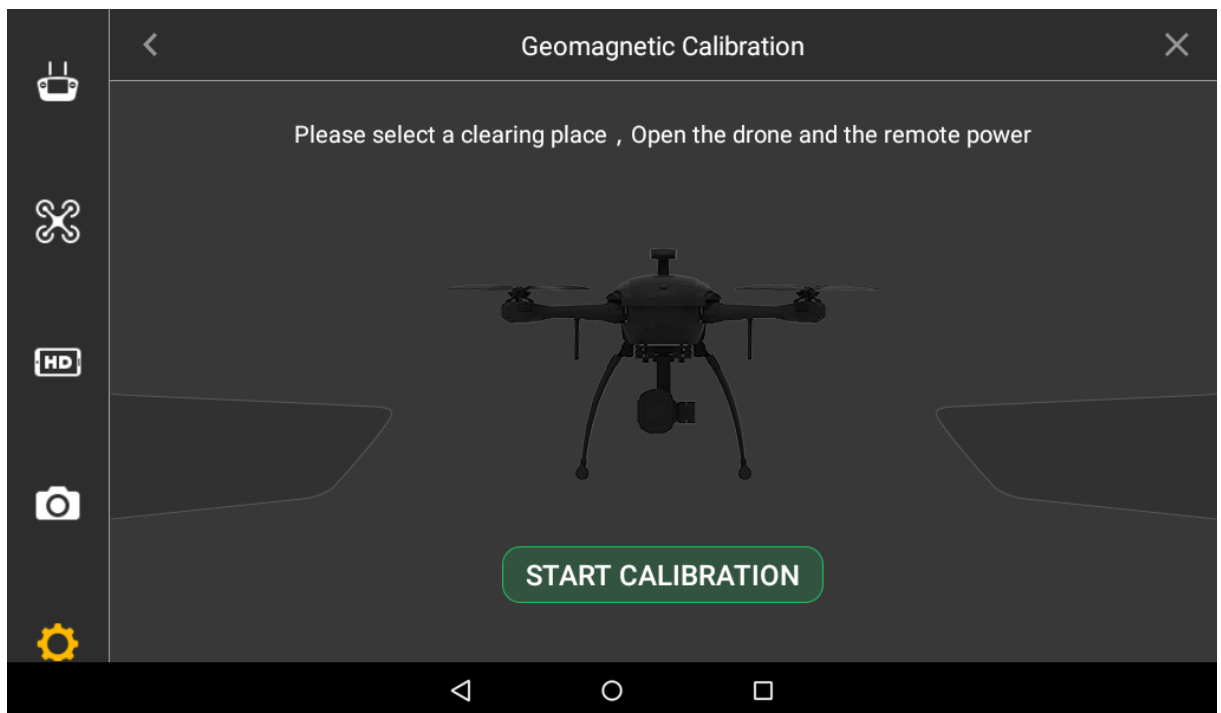

Figure 3-28

- Step 2 Click “Start Calibration”.

- Step 3 Keep the aircraft horizontal and rotate it for 360° horizontally, as shown in Figure 3-29.

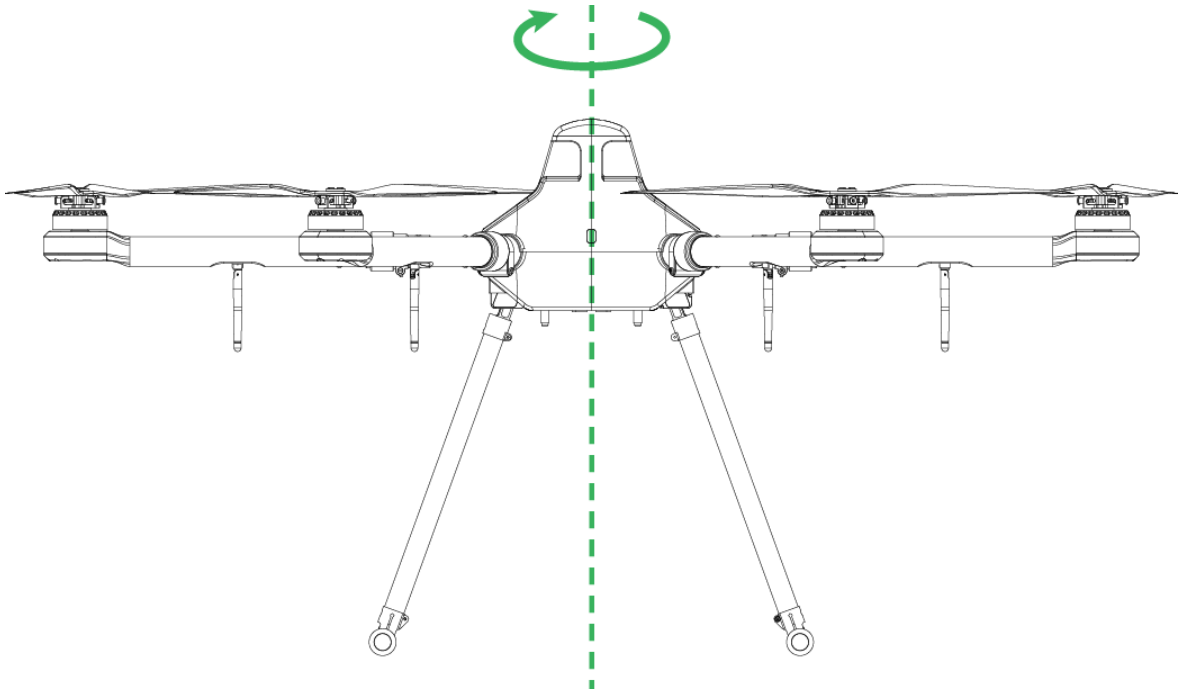

Figure 3-29

Step 4 Keep the aircraft vertical and rotate it for 360° vertically, as shown in Figure 3-30.

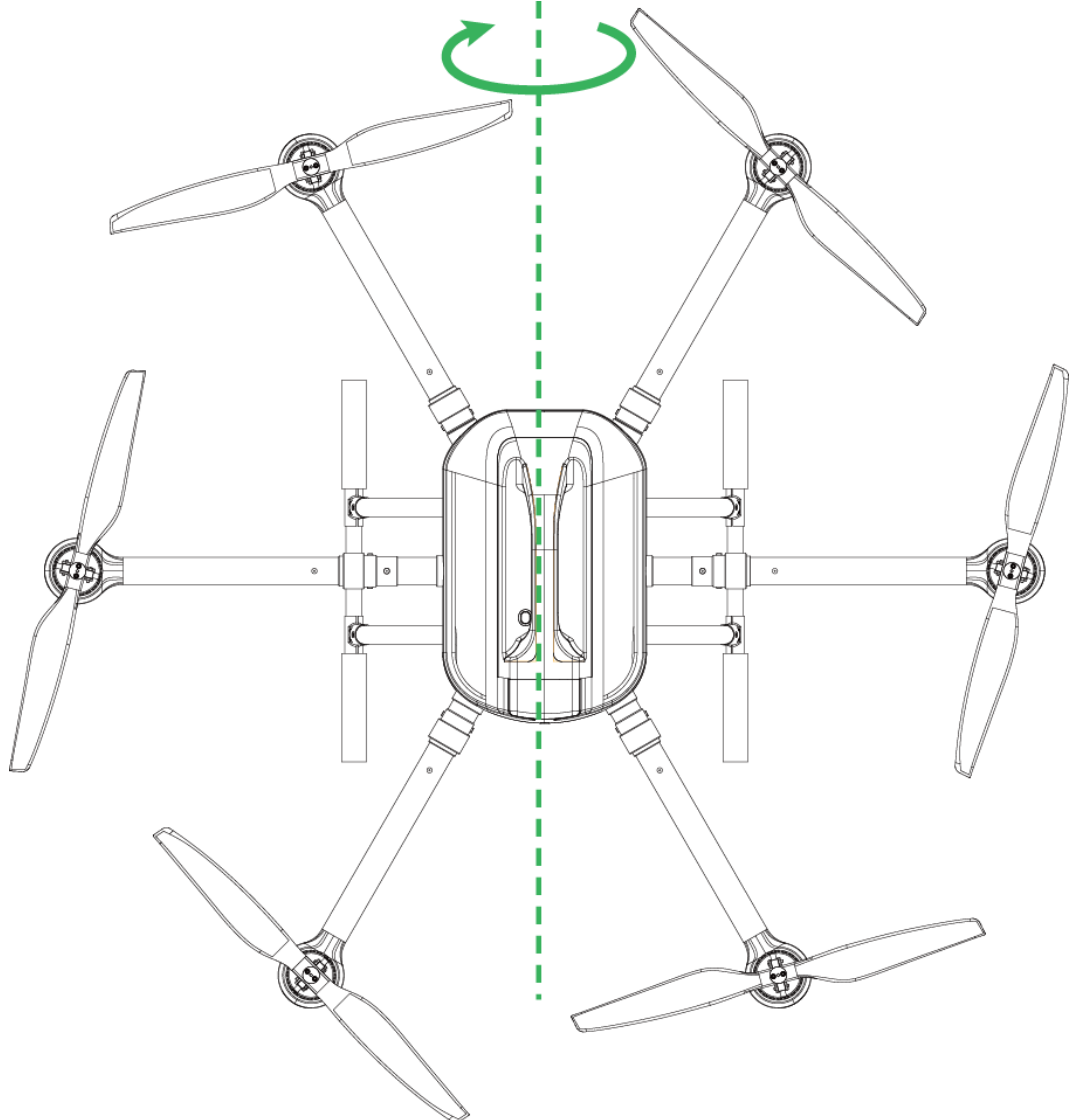



Figure 3-30

- It will prompt geomagnetic calibration success if it is successfully calibrated.
- It will prompt geomagnetic calibration failure if it fails to calibrate. Repeat Step 2, 3 and 4 to calibrate again.

### 3.8.5 GPS Satellites Insufficiency

#### Abnormity Prompt

- Displayed number of satellites of remote control is less than 6.
- GPS HDOP:  at the top status bar of remote control is less than 1 bar or there is no signal.

#### Possible Reasons

- The flying environment is not wide open enough, which is severely blocked.
- There is some other interference around the surroundings.

#### Solutions

Move the aircraft to a wider area and wait for 30s.

## 3.9 Install Propellers

Step 1 Press the spring buckle on both sides of the propeller center, as shown in Figure 3-31.

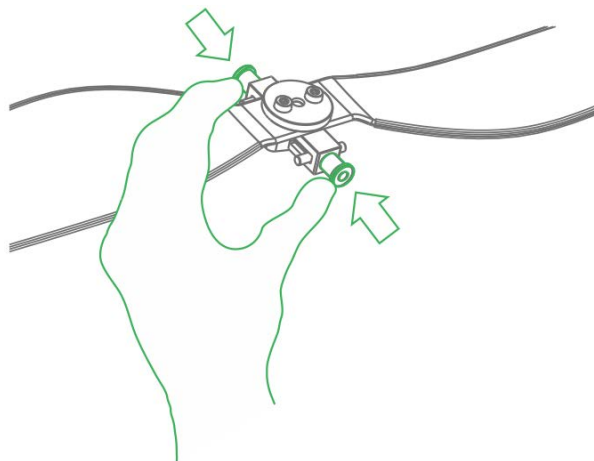

Figure 3-31

Step 2 Buckle the latch on the motor, as shown in Figure 3-32.



**Note** Structures of 2 types of propellers are different. Adjust to the adjacent motor position to install if it fails to buckle.

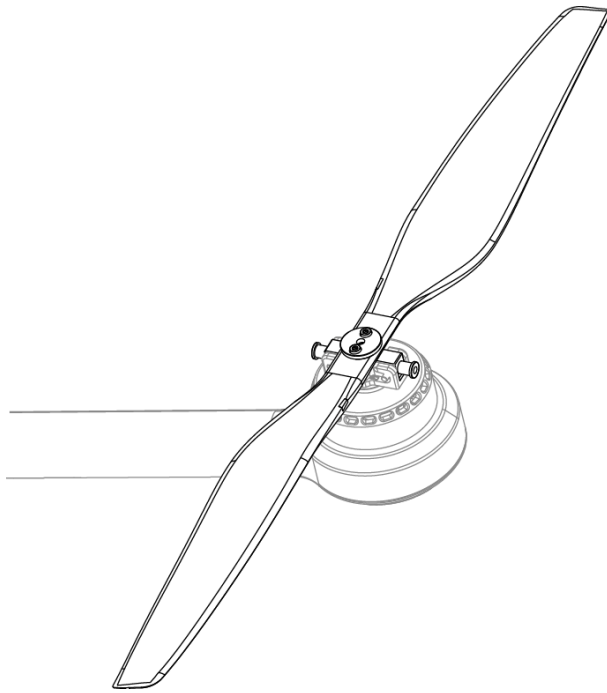

Figure 3-32

# 4 Enable Flight

## Note

This chapter will elaborate the complete flow of formal takeoff and landing of the aircraft.

## Danger

Please stay away from the rotating propellers or motor, to avoid personal injury.

## Warning

For your personal and property safety, please make sure to check the following items carefully before enabling flight.

- Flight preparations listed in Chapter 3 are all completed.
- All the components have been correctly and stably installed.
- Make sure that each spare part is in good condition. Please do not fly the aircraft if some parts are aged or damaged.
- Flight environment meets the requirements listed in important safeguards and warnings.

## Caution

Please do not block the ventilation near heat dissipation hole when the motor is operating.

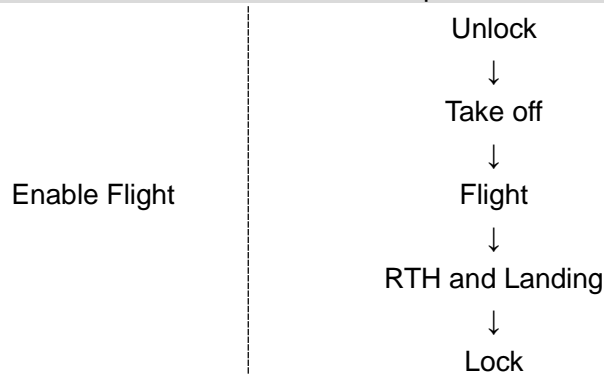

Figure 4-1

This chapter will introduce manual and intelligent flight mode separately.

Switch between these two modes. For example, you can use one-key takeoff and landing buttons in the manual flight mode.

## 4.1 Flight Mode

Control flight mode via driving lever during flight phase, as shown in Figure 4-2.

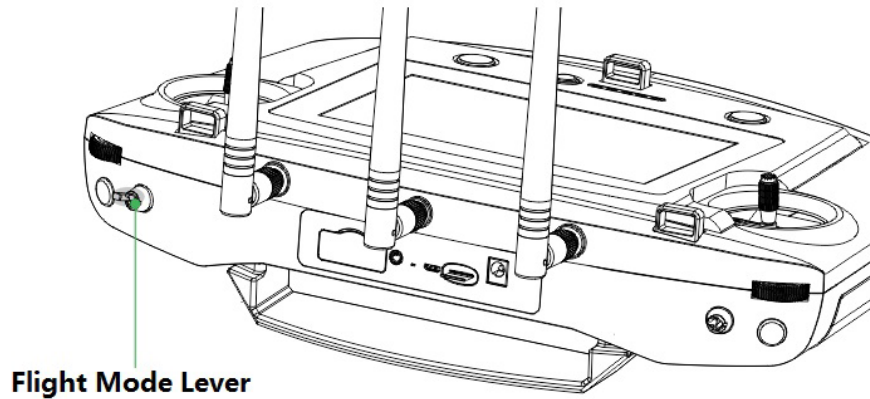

Figure 4-2

Three-level driving lever:

- Upper level: Intelligent flight mode. The aircraft will fly automatically according to the pre-set flight route.
- Medium level: It is the fixed height flight mode in manual flight mode. The aircraft will maintain the current flight height when the throttle joystick is in the middle.
- Lower level: Fixed point flight mode in manual flight mode. The aircraft will maintain the current location when all sticks are located in the middle.

## 4.2 Manual Mode

### 4.2.1 Introduction to Manual Flight Flow

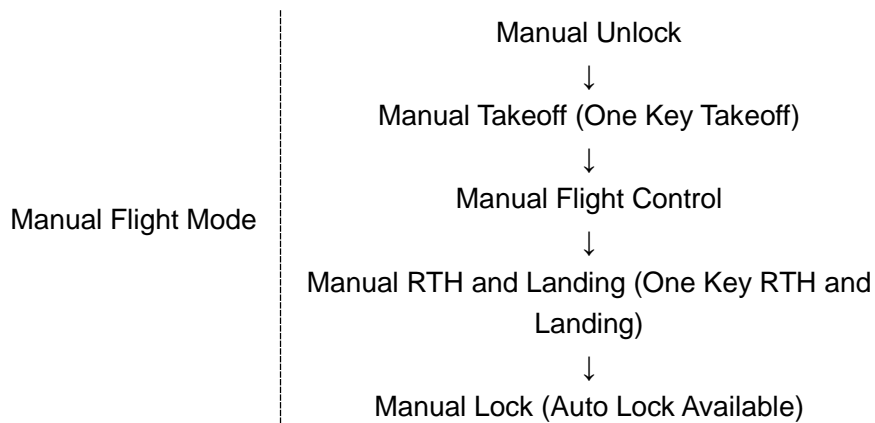
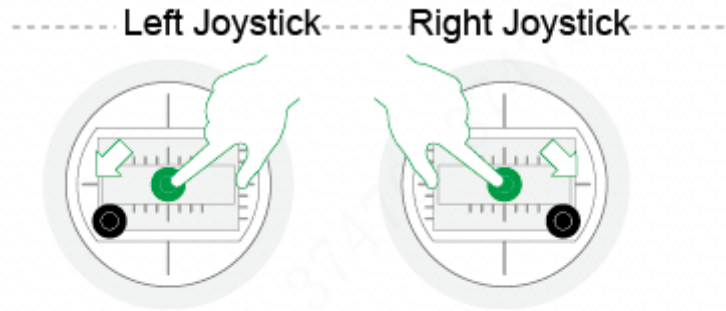

Figure 4-3

### 4.2.2 Unlock Flight Control

Move the left joystick to lower left, meanwhile move the right joystick to lower right (or move the left joystick to lower right, meanwhile move the right joystick to lower left), and keep the status for 2s. At this moment, the propellers are unlocked and start to rotate. Move all the sticks back to middle, as shown in Figure 4-4.

## Mode 1



## Mode 2

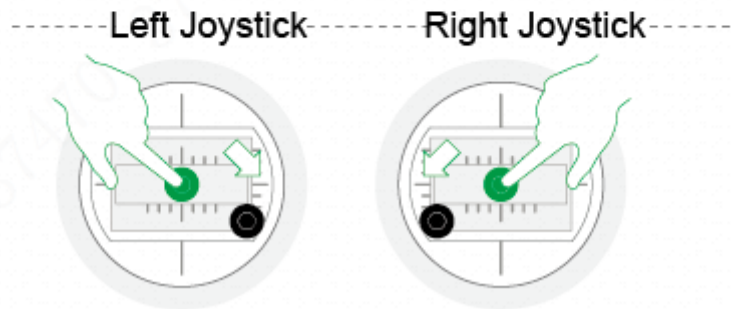

Figure 4-4

### ! Caution

- If there is obvious difference about rotating speed of the propellers, move the left joystick to lower left and meanwhile move the right joystick to lower right (or move the left joystick to lower right, and meanwhile move the right joystick to lower left), and then keep the status till the propellers stop rotating. Turn off the aircraft and contact our company.
- The aircraft will be automatically locked if it stays on the ground and doesn't take off within 10s after it is unlocked.

## 4.2.3 Manual Takeoff

Slightly push the throttle to mid-point or higher, as shown in Figure 4-5.

----- Throttle Joystick -----



Figure 4-5

## 4.2.4 Manual Flight Control

Set remote control mode and control flight direction of the aircraft.

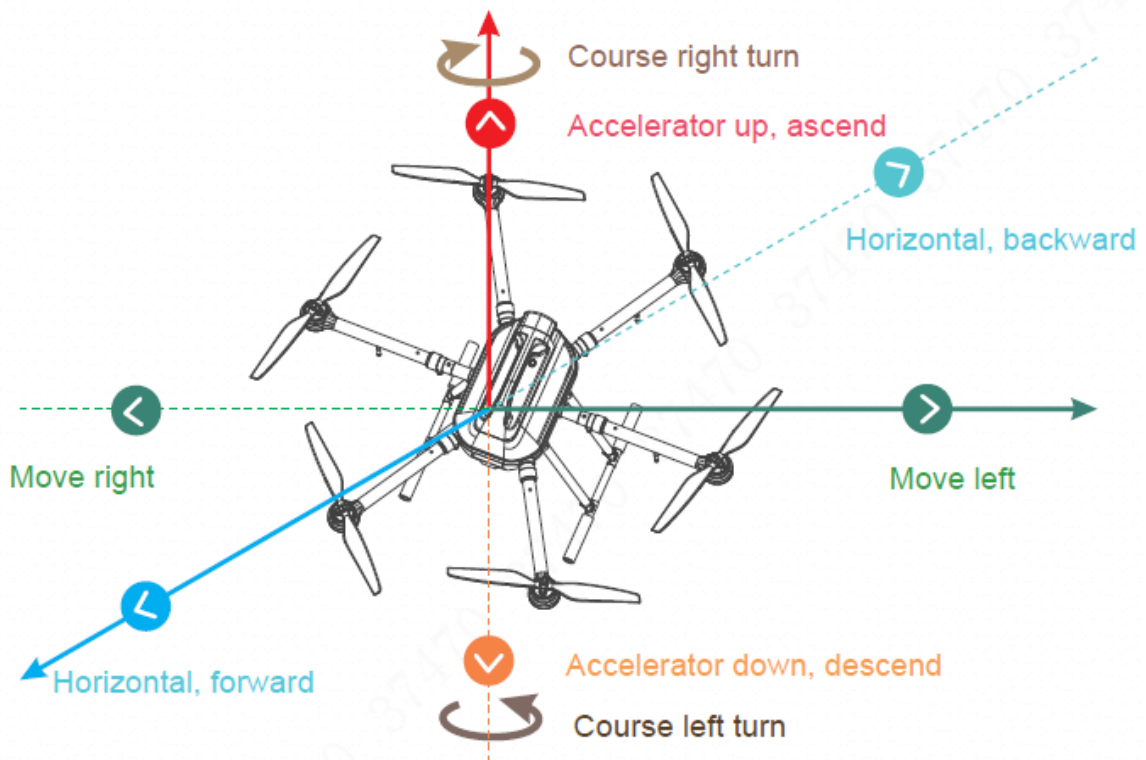

Figure 4-6

The joystick presets two remote control modes.

It is mode 2 by default. Please modify in "Settings > Remote Control Settings > Joystick Mode" to switch to mode 1.

- Mode 1:
  - ◇ Vertical direction of left joystick is pitching joystick, which controls the aircraft to go forward and backward horizontally.
  - ◇ Horizontal direction of left joystick is course joystick, which controls the aircraft to



make left and right turn horizontally.

- ◇ Vertical direction of right joystick is throttle joystick, which controls the aircraft to ascend and descend.
- ◇ Horizontal direction of right joystick is rolling joystick, which controls the aircraft to move left and right horizontally.

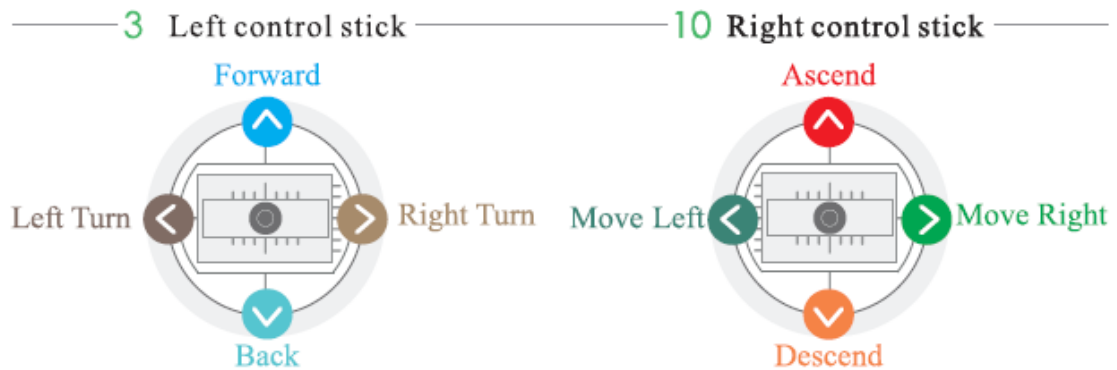

Figure 4-7

- Mode 2:
  - ◇ Moving the left joystick up and down (throttle joystick) to control aircraft's ascending and descending.
  - ◇ Moving the left joystick left and right (course joystick) to control aircraft's left and right turn horizontally.
  - ◇ Moving the right joystick up and down (pitching joystick) to control aircraft's forward and backward movement horizontally.
  - ◇ Moving the right joystick left and right (rolling joystick) to control aircraft's left and right movement horizontally.

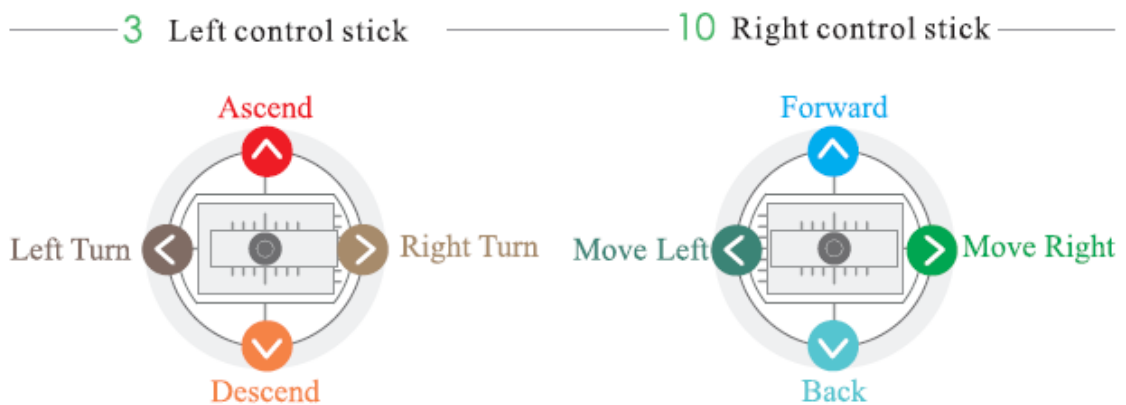

Figure 4-8

## 4.2.5 Manual RTH and Landing

- Manual RTH: Control the aircraft to hover over a proper landing point.
- Manual landing: Reduce the throttle to make the aircraft land slowly.

-----Throttle Joystick -----



Figure 4-9

### 4.2.6 Manual Locking

Move the left joystick to lower left and move the right joystick to lower right at the same time (or move the left joystick to lower right and move the right joystick to lower left at the same time).

#### Mode 1

-----Left Joystick ----- Right Joystick -----

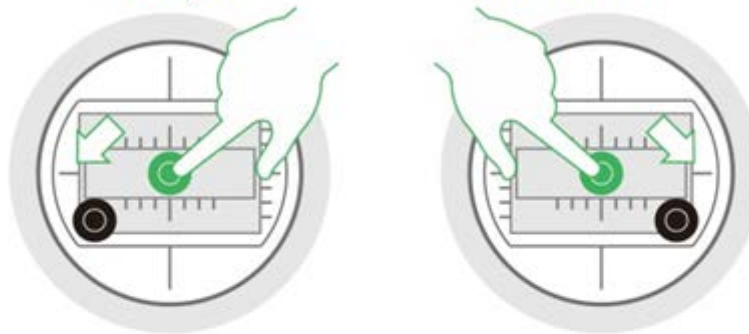

#### Mode 2

-----Left Joystick ----- Right Joystick -----



Figure 4-10

## 4.3 Intelligent Mode

### 4.3.1 Intelligent Flight Mode

Intelligent flight mode includes waypoints and circle around point of interest.

- Waypoints flight: Set waypoint flight mission according to requirements. Move the flight mode joystick at right rear of remote control to intelligent mode after the aircraft takes off, select proper flight mission and click “Start Mission”.
- Circle (around point of interest) flight: Set circle flight mission according to requirements. Move the flight mode joystick at right rear of remote control to intelligent mode after the aircraft takes off, select proper flight mission and click “Start Mission”.

#### Note

- When the flight mode joystick of remote control is moved to any mode (point, elevation or intelligent mode), you can set waypoint flight or circle flight and save flight mission.
- The aircraft is allowed to implement flight mission only when the flight mode joystick of remote control is moved to the intelligent mode (Mode F).
- It can realize waypoint flight or point of interest circle flight only after the aircraft takes off, and it can't be realized on the ground.

Click the  button on the main interface of the remote control, and enter the interface of intelligent flight mode, as shown in Figure 4-11.

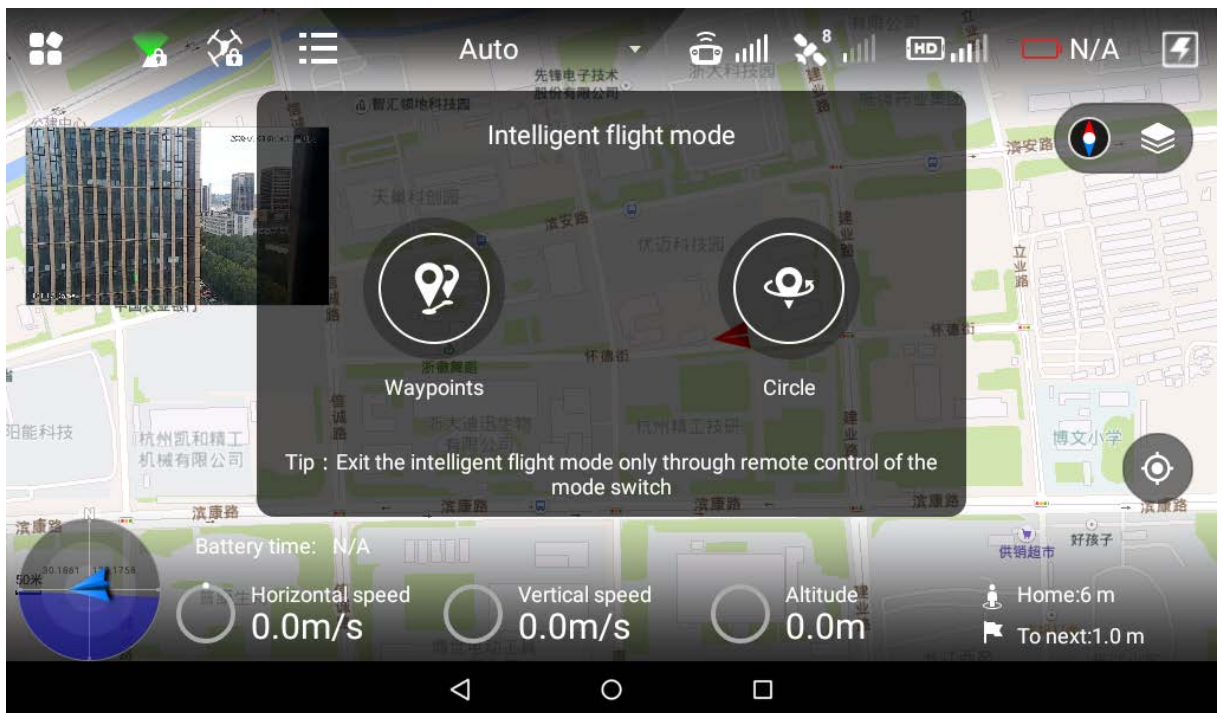

Figure 4-11

### 4.3.1.1 Waypoints

Step 1 Select “Waypoints”.

The system displays “Waypoints” interface, as shown in Figure 4-12.



Check total route length, estimated flight time and set “Cycle Flight” at the bottom of the interface.

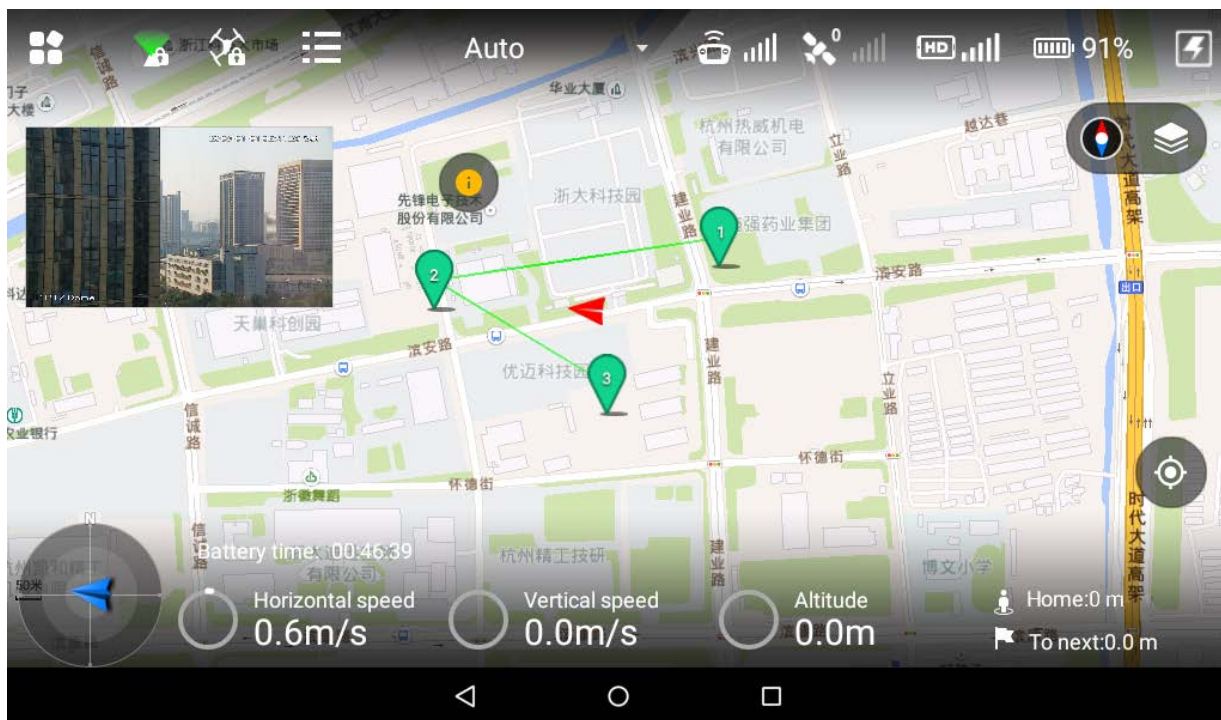

Figure 4-12

Step 2 Click the map and the position can be set as a waypoint; several waypoints can be connected together and form a route.



Check total route length, estimated flight time and set “Cycle Flight” at the bottom of the interface.

Step 3 Click a waypoint and it will become red. Waypoint setting interface will display on the right of the interface, as shown in Figure 4-13.

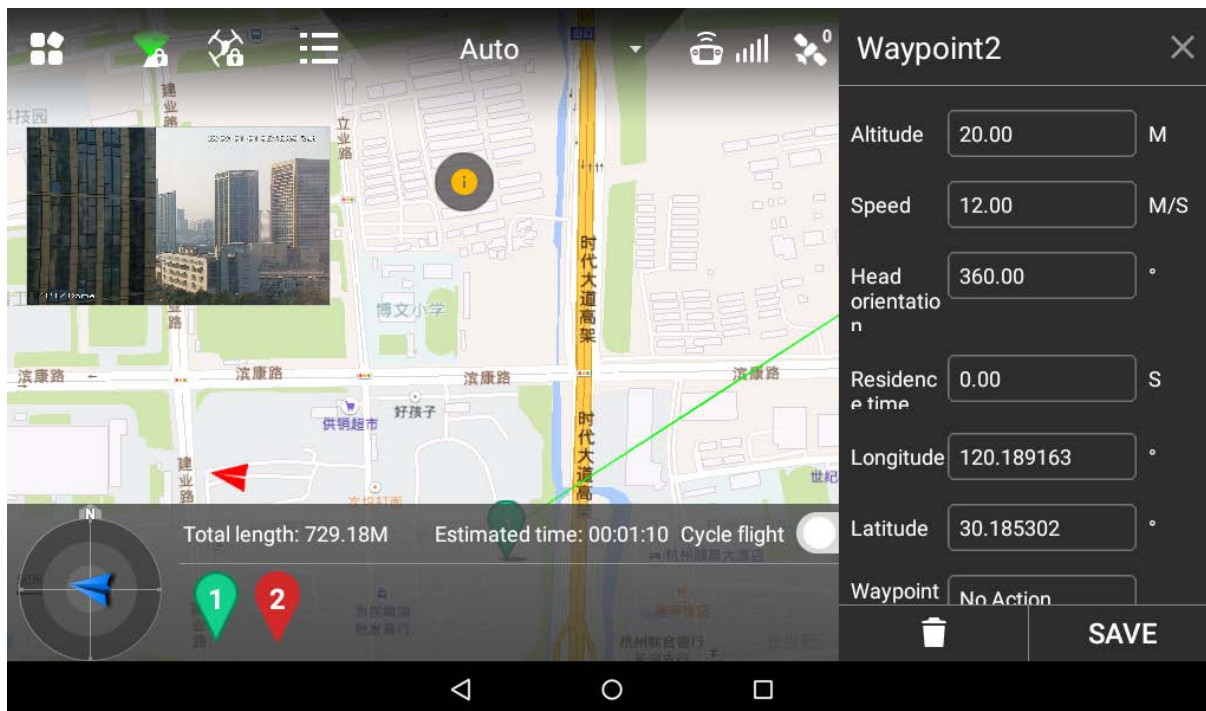

Figure 4-13

Step 4 Set waypoint parameters. Please refer to Table 4-1 for more details.



Parameter	Note
Altitude	Set flight altitude of waypoint.
Speed	Set flight speed of waypoint
Head orientation	Set head orientation of waypoint according to requirement during flight.
Residence time	Set hovering time after the aircraft reaches a waypoint.
Latitude and longitude	<ul style="list-style-type: none"> <li>Automatically acquire latitude and longitude of the waypoint when adding the waypoint.</li> <li>Manually set waypoint latitude and longitude. Waypoint position will skip to manual setting point after setting is done.</li> </ul>
Waypoint action	<ul style="list-style-type: none"> <li>No action: it is not to set waypoint action.</li> <li>Shutter: it will take photos after the aircraft arrives at the waypoint.</li> </ul>
Action cycle	<ul style="list-style-type: none"> <li>Action cycle setting is invalid when the waypoint action selects "No Action".</li> <li>When waypoint action selects "Shutter", input time. The aircraft arrives at the waypoint and it will take a photo after a period of time.</li> </ul> <p> Note</p> <p>Action cycle shall be less than or equal to residence time.</p>

Table 4-1

Step 5 Click "Save" to make configuration valid.



Click  to set waypoint parameters in batches. Meanwhile, it can modify or delete several waypoints.

Step 6 Click  to input mission name, click "Save" and you can check saved flight missions



in the list.



Click  to enter flight mission interface. There are three operations:

- Add mission: Click the icon to enter waypoint setting interface, set waypoint flight mission and save it according to actual requirements.
- Download mission: Click the icon to automatically download the currently saved flight route. You can modify the waypoint according to actual requirement and save it into the remote control.
- Select mission: Click the icon, select one or more missions on the interface, and delete the mission(s).

### 4.3.1.2 Circle

Step 1 Select "Circle".

The system displays "Circle" interface, as shown in Figure 4-14.

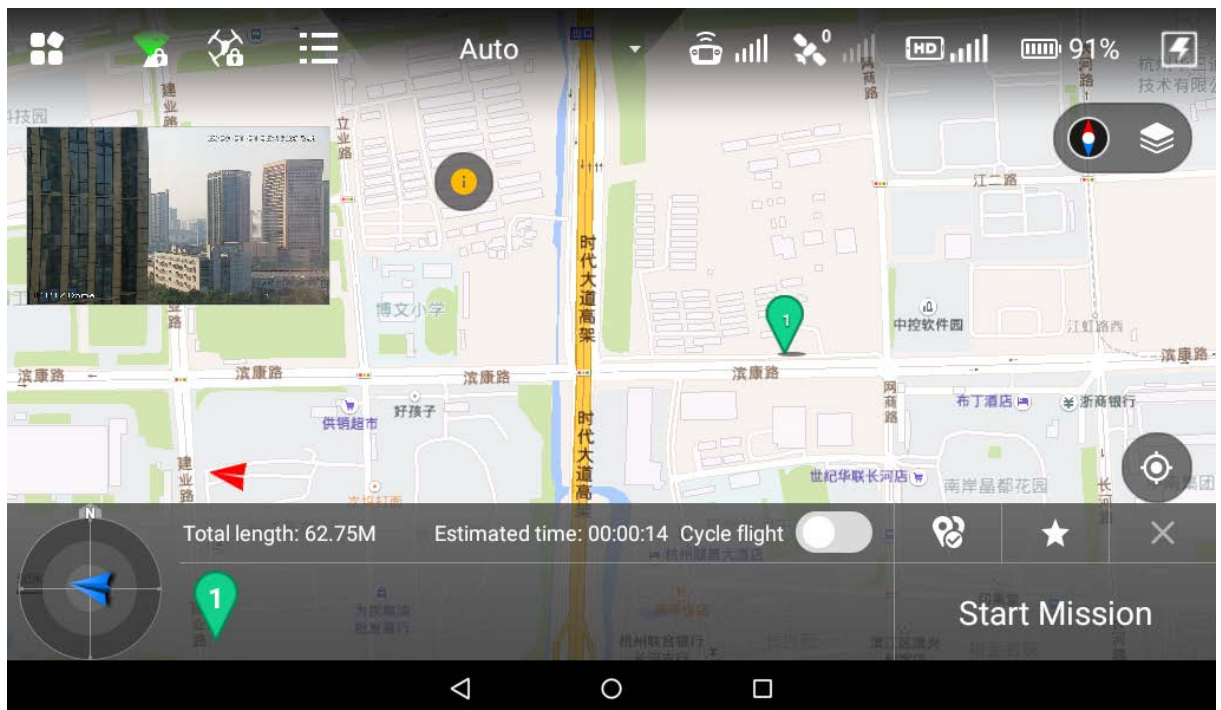

Figure 4-14

Step 2 Click the map and the position can be set as interest point.

Step 3 Click the interest point, and the point icon will become red. Settings interface of interest point will be displayed on the right of main interface, as shown in Figure 4-15.

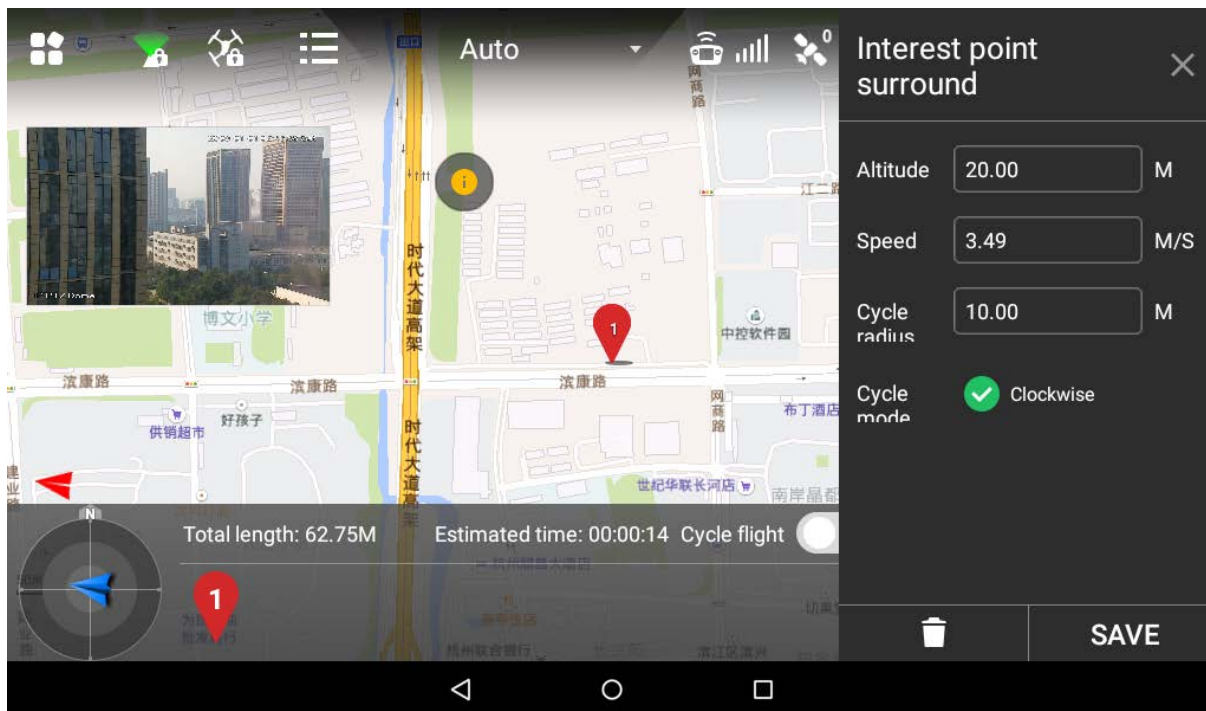

Figure 4-15

Step 4 Set the parameters of interest point. Please refer to Table 4-2 for more details.

Parameter	Note
Altitude	Set flight altitude of interest point.
Speed	Set flight speed of interest point.
Cycle radius	Set flight radius of aircraft flying around interest point.
Cycle mode	Select the flight direction of aircraft flying around interest point, clockwise optional.

Table 4-2

Step 5 Click “Save” to make configuration valid.



Set one interest point only for each flight mission.

Step 6 Click  to input mission name, click “Save” to save flight mission.

### 4.3.2 Intelligent Locking Mode

Step 1 Click  and it will pop out a dialog box. Select locking mode of the aircraft.

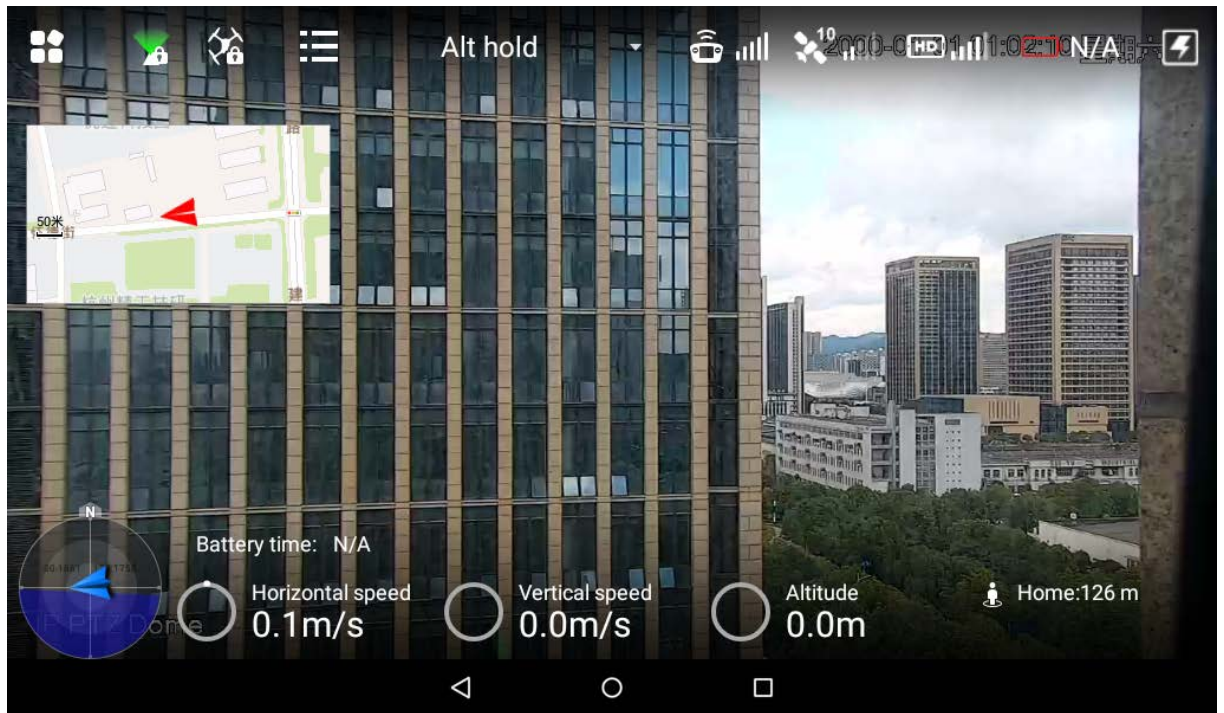

Figure 4-16

There are two types of intelligent locking modes, namely course lock and return lock.

- Course lock: Click it to lock the present head direction as its forward direction. During the following flight process, the aircraft course has nothing to do with the head direction; the aircraft will always move forward according to the locked head direction.
- Return lock: Click it and the aircraft course has nothing to do with the head direction. Always take the straight line direction far away from HOME point as forward direction and the straight line direction close to HOME point as backward direction.

If both modes are canceled: the aircraft head direction is forward direction.

Step 2 Click “Return Lock” and the icon becomes yellow, and it will prompt “Return Lock Enabled”.

Click “Course Lock” and the icon becomes yellow, and it will prompt “Course Lock Enabled”.

## 4.3.3 Intelligent Operation

### 4.3.3.1 Auto Takeoff

In fixed point mode, first unlock flight control, and then short press the takeoff and landing button on the front panel of the remote control. The aircraft will take off automatically and begin flight according to the pre-set route.



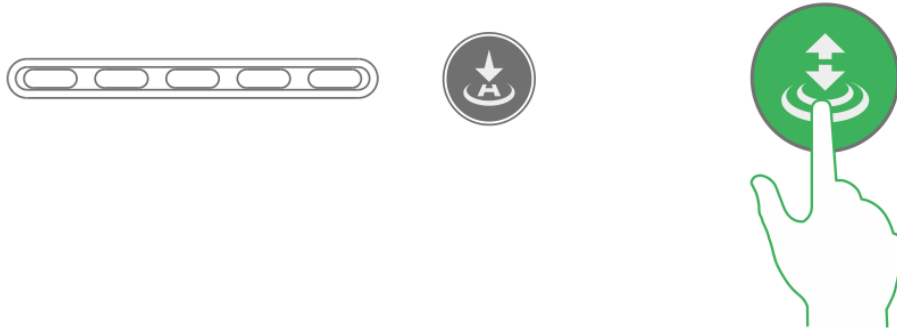

Figure 4-17

### 4.3.3.2 Auto RTH and Landing

 Note

The landing under the condition of low battery or in the uncontrollable situation has been introduced in other chapters; this chapter will only introduce the landing modes in other situations.

Short press RTH button on the front panel of the remote control, and the aircraft will return to Home.

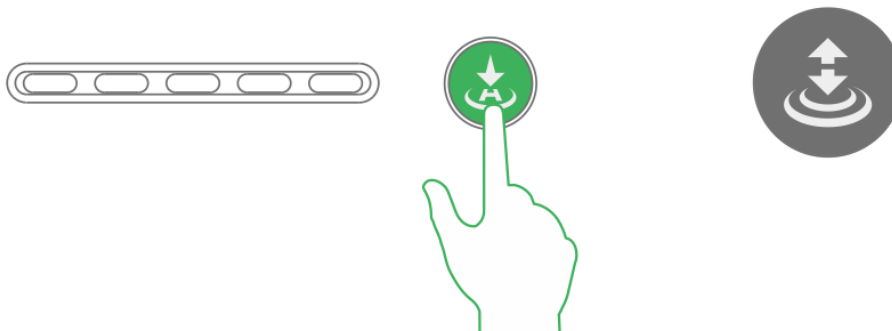

Figure 4-18

### 4.3.3.3 One-key Landing

Under the present condition, the aircraft needs to land vertically.

Short press the takeoff and landing button on the front panel of the remote control, and the aircraft will land at the current position automatically.

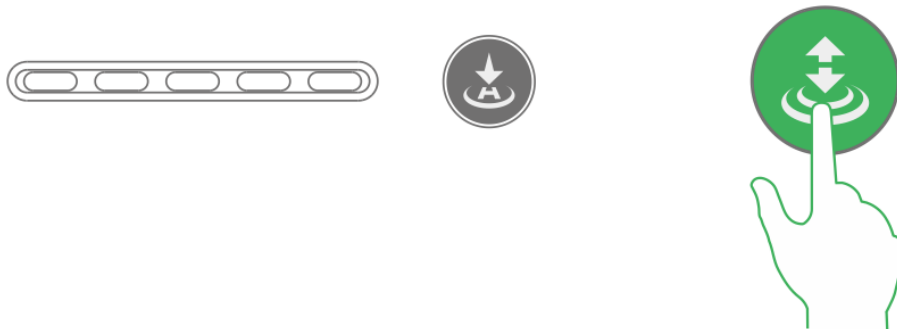

Figure 4-19

 Note

One-key landing doesn't return Home, but the aircraft will land at the current position immediately.

## 4.4 Intelligent Protection Mechanism

### 4.4.1 Low Battery

There are totally three prompts of aircraft low battery for the remote control, and each prompt is more serious than the previous one.

- Level-one low battery, remote control prompts message: “Low Voltage Alarm”, along with alarm sound.
- Level-two low battery, remote control prompts message: “Serious low voltage home”, along with alarm sound. First ascend to 120m, return to HOME point and then descend. At this time, it is OK to suspend low voltage home (cancel button appears on App, or suspend it by switching the mode of remote control continuously).
- Level-three low battery, remote control prompts message: “Serious low voltage landing”, along with alarm sound. Meanwhile, the aircraft triggers landing mode.



Note

After suspending low voltage home, level-three low battery alarm will be triggered if it continues to fly or fly in some harsh environment.

### 4.4.2 Out of Control

- The aircraft may run into the following out of control situations:
  - ◇ The aircraft or remote control antenna is damaged, and it fails to receive and send signals.
  - ◇ Intensive magnetic field arises in ambient environment, which interferes with the aircraft and remote control.
- Solutions:
  - Out of control auto return: ascend the aircraft to 120m first and then return to HOME point.

## 4.5 Remote Control Setting

### 4.5.1 Remote Button User-defined

Set the function of A1 button on the remote control, including “One button to return to center” and “One button 90°”.

Select “Settings > Flight Control Settings > Remote Control Settings > Remote Button User-defined”. The system displays “Remote Button User-defined” interface, as shown in Figure 4-20.

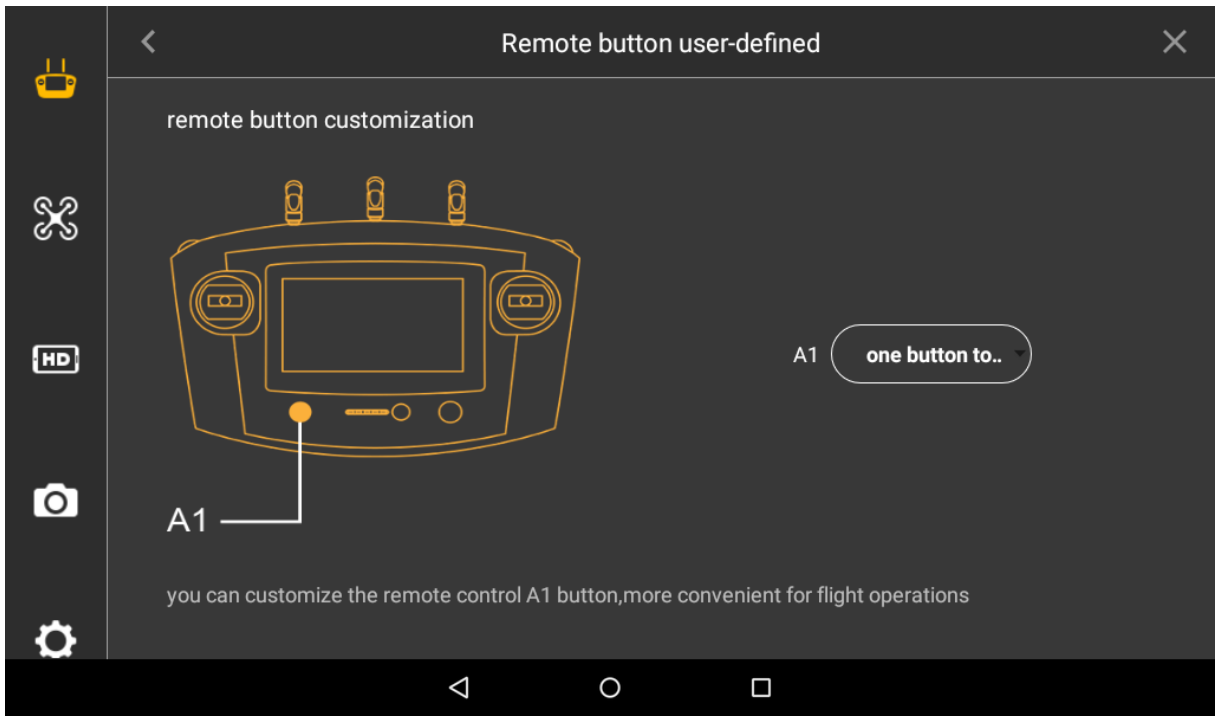

Figure 4-20

## 4.5.2 Flight Control Settings

### 4.5.2.1 Fence Settings

Select “Settings > Flight Control Settings > Fence Settings”. The system displays “Fence Settings” interface, as shown in Figure 4-21.

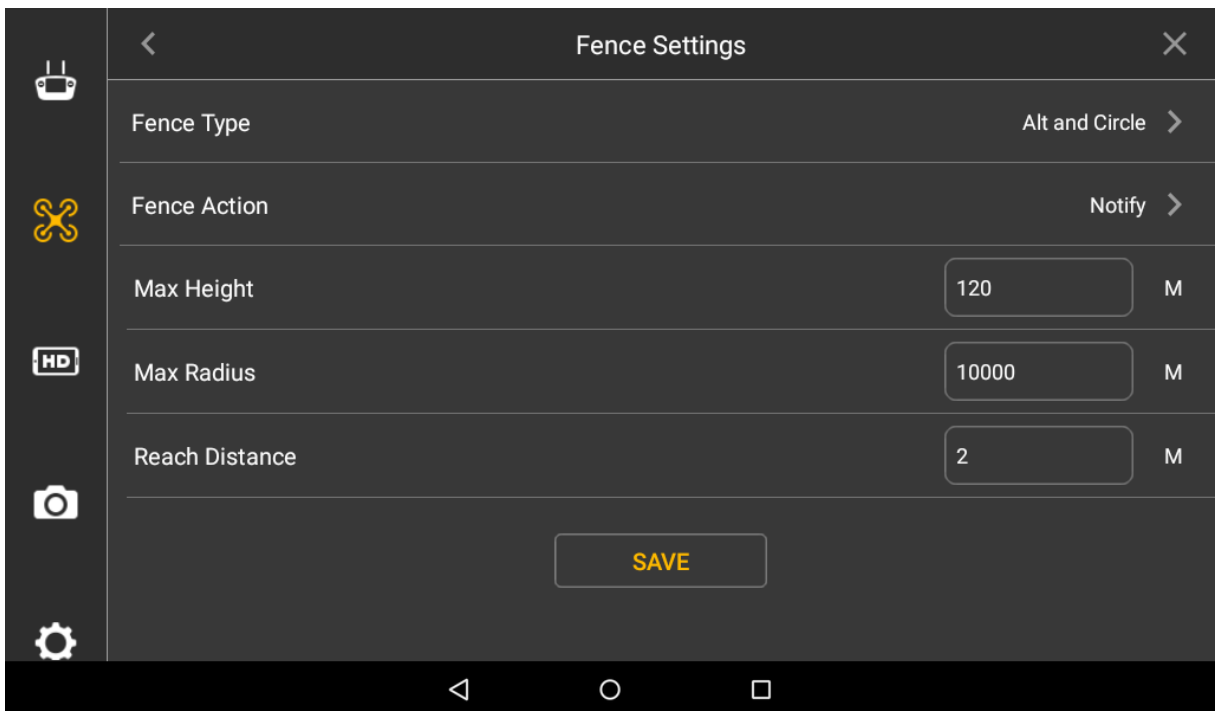

Figure 4-21

#### 4.5.2.1.1 Fence Type

Draw electronic fence area.

Select “Settings > Flight Control Settings > Fence Settings > Fence Type”, as shown in Figure 4-22.

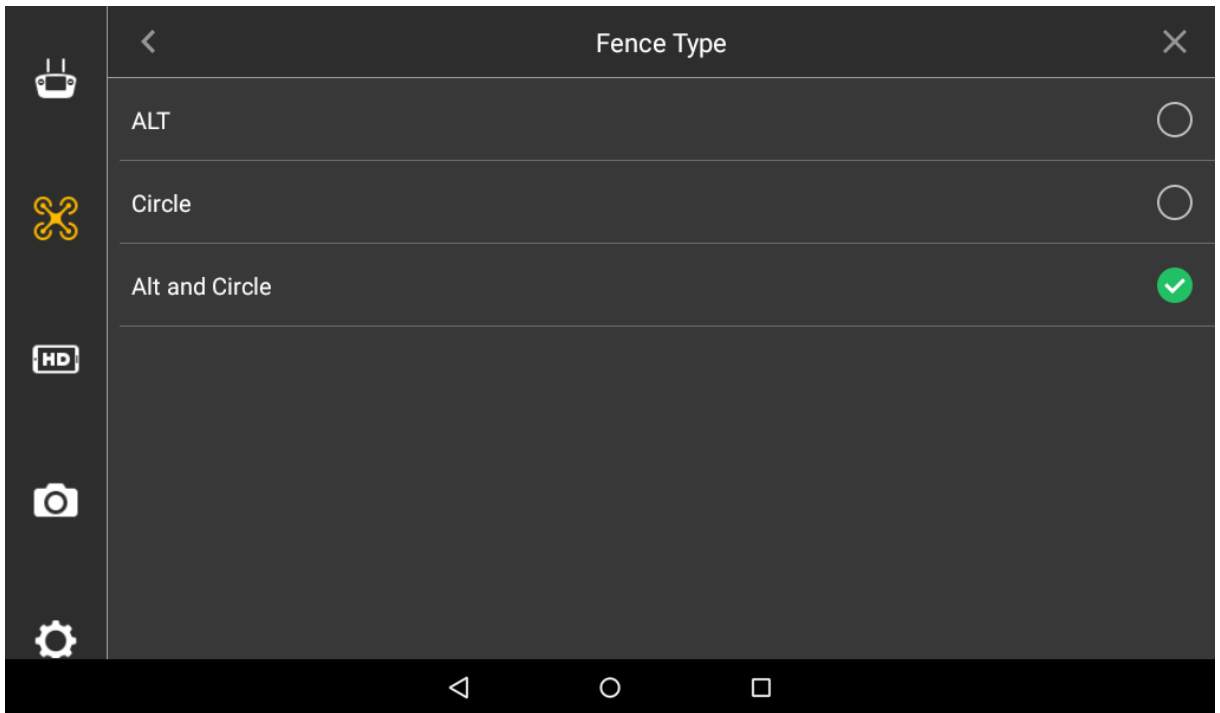

Figure 4-22

- ALT (Limited altitude): limit the max. flight altitude of the aircraft, but there is no limit in horizontal direction of the aircraft.
- Circle: Take HOME point as circle center and the set value as radius. The aircraft is restricted to fly within the circle, and there is no limit to the altitude.
- ALT and Circle: Take HOME point as circle center and set value as radius. The set height is considered as max. flight altitude; the aircraft is restricted to fly within the cylindrical area.

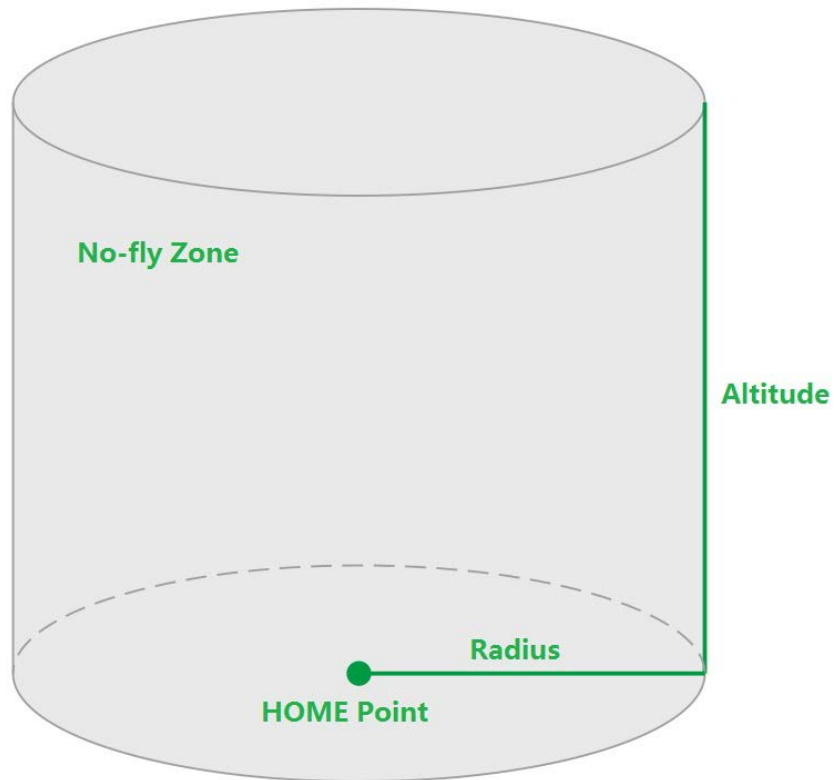

Figure 4-23

#### 4.5.2.1.2 Fence Action

Select “Settings > Flight Control Settings > Fence Settings > Fence Action”, as shown in Figure 4-24.

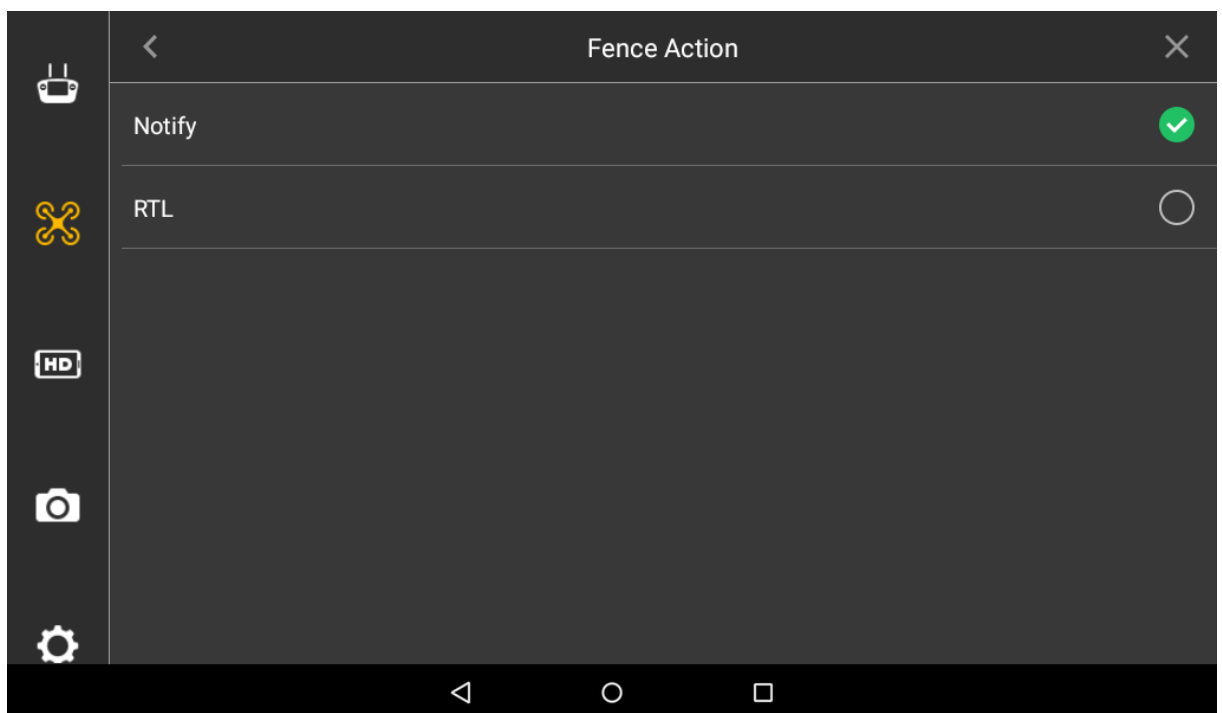

Figure 4-24

- Notify: The aircraft hovers in the air when electronic fence is triggered. Preview interface of remote control gives a prompt, along with buzzing.
- RTL: When electronic fence is triggered, preview interface of remote control gives a

prompt, along with buzzing. Meanwhile, the aircraft returns automatically.

#### 4.5.2.1.3 Other Settings

Select “Settings > Flight Control Settings > Fence Settings”.

- Set radius and altitude.
- Set trigger distance.

For example, when the fence type is set as radius + altitude, the radius is set as A meters and altitude is set as B meters, and if the trigger distance is set as C meters, then it will trigger RTH or landing when the aircraft is (A-C) meters away from the HOME point horizontally or flight altitude exceeds (B-C) meters; the aircraft will implement the action of RTH or landing.

#### 4.5.2.2 Enable Electronic Fence

Enable electronic fence after setting fence area.

Select “Settings > Flight Control Settings”, enable electronic fence on the right of the “Fence Enable”.



Figure 4-25

#### 4.5.3 Preview Settings

Set resolution, frame rate and max. bandwidth of preview image according to requirements.

Step 1 Select “Settings > Flight Control Settings > Preview Settings” and enter the preview setting interface, as shown in Figure 4-26.

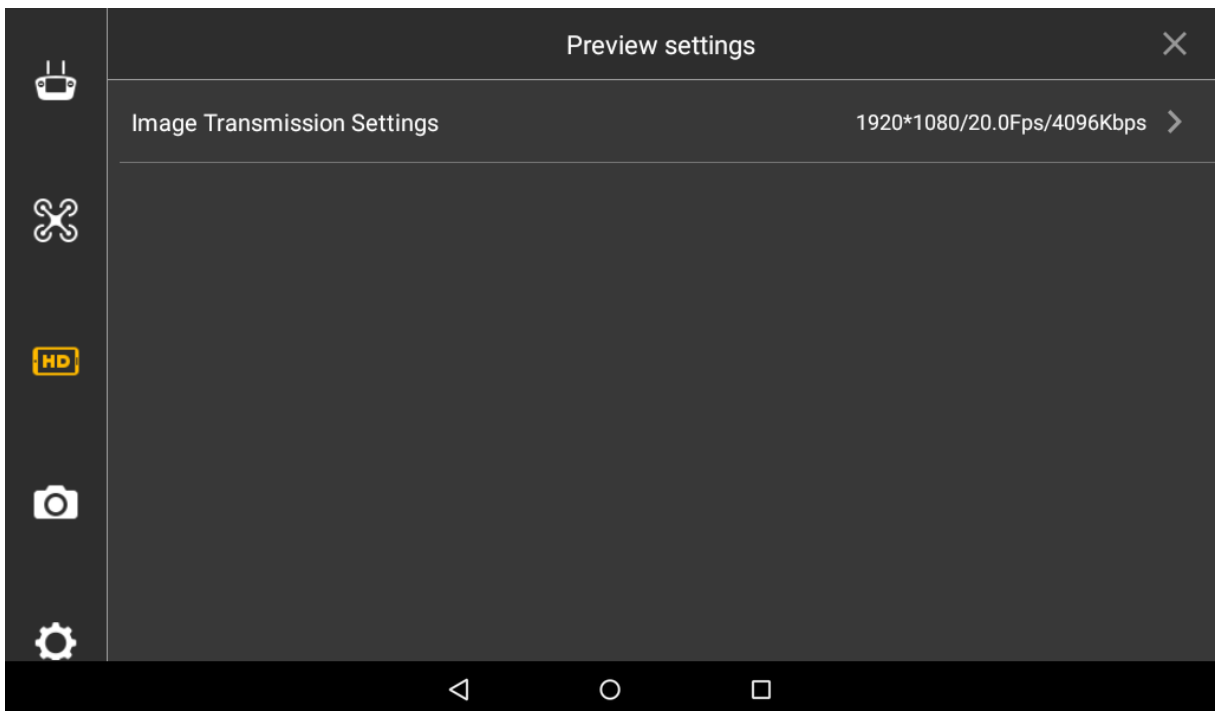

Figure 4-26

Step 2 Select “Settings > Flight Control Settings > Preview Settings > Image Transmission Settings”.

The system displays “Image Transmission Settings” interface, as shown in Figure 4-27.

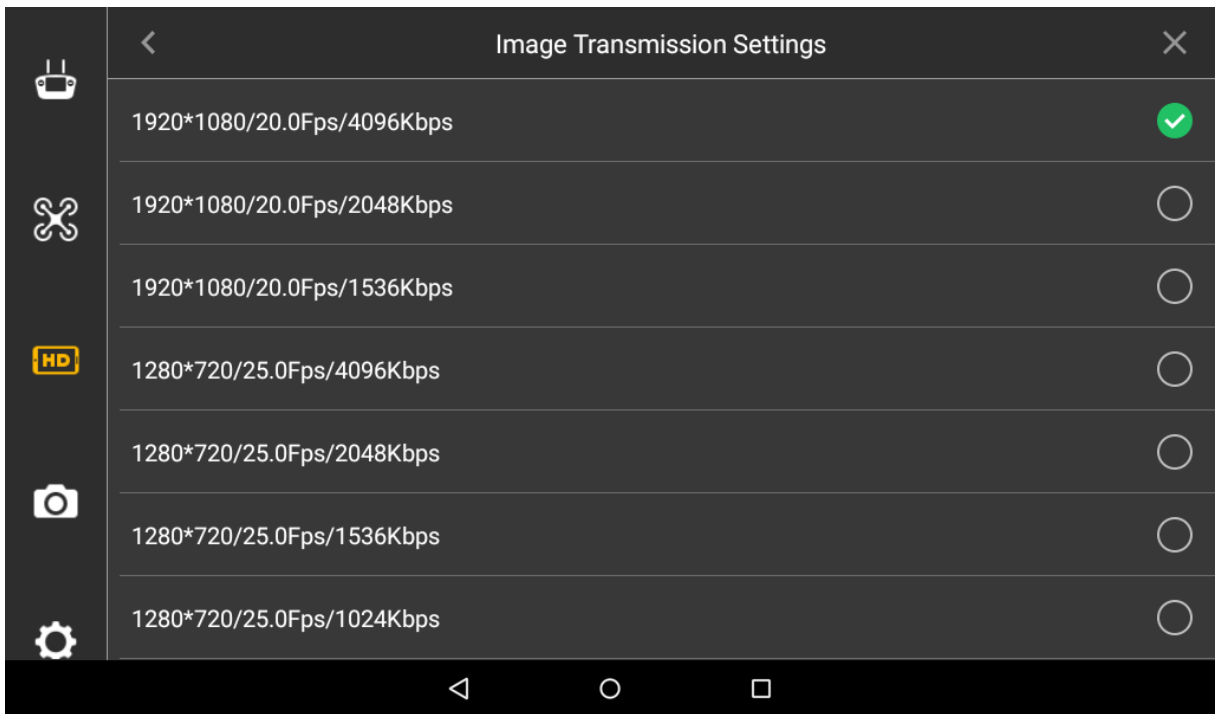

Figure 4-27

Step 3 Select one option.

Icon at the end of selected line becomes green and checked, which makes it valid immediately.

## 4.5.4 Camera Settings

### 4.5.4.1 Photo Settings

Set resolution, frame rate and max. bandwidth of photos taken by PTZ camera according to requirements.

Step 1 Select “Settings > Camera Settings > Photo Settings”.

The system displays “Photo Settings” interface, as shown in Figure 4-28.

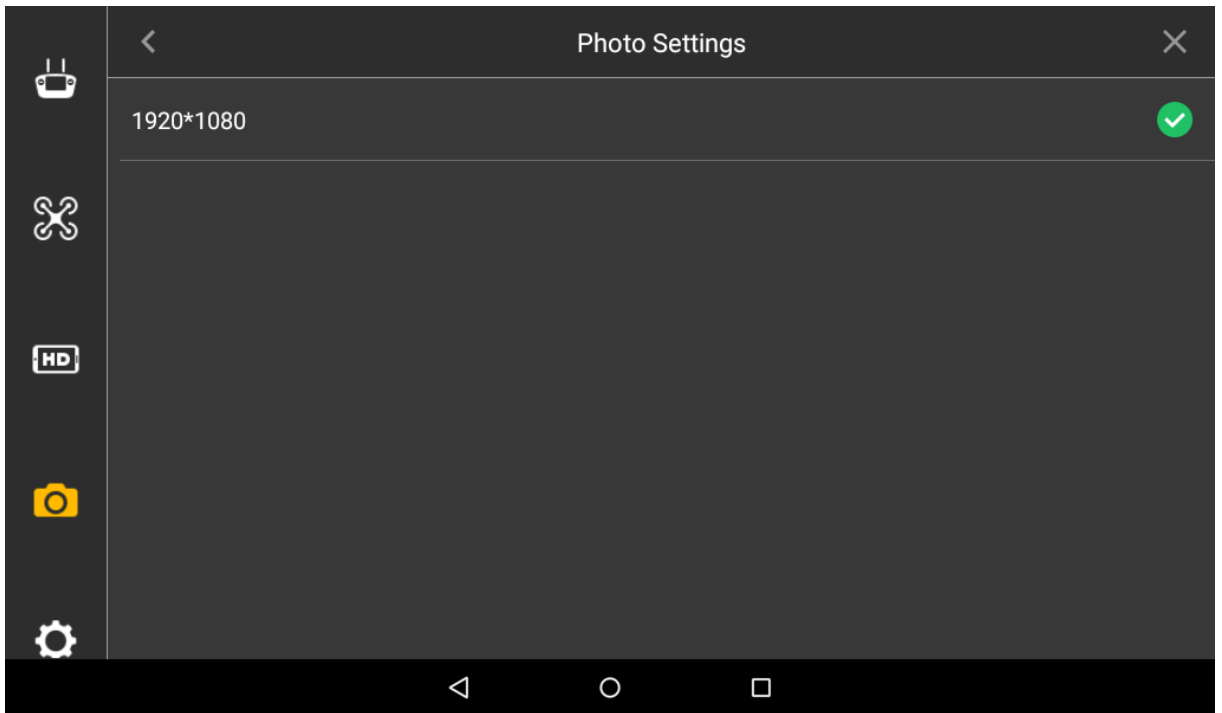

Figure 4-28

Step 2 Select one line.

Icon at the end of selected line becomes green and checked, which makes it valid immediately.

#### 4.5.4.2 Video Settings

Select to enable “Camera Auto-take Video When Unlock” or not; select the resolution, frame rate, stream and coding format of PTZ camera.

##### Note

Please ensure that the aircraft is unlocked during video setting. Video setting can be realized only under unlocked status.

Step 1 Select “Settings > Camera Settings > Video Settings”.

The system displays “Video Settings” interface, as shown in Figure 4-29.



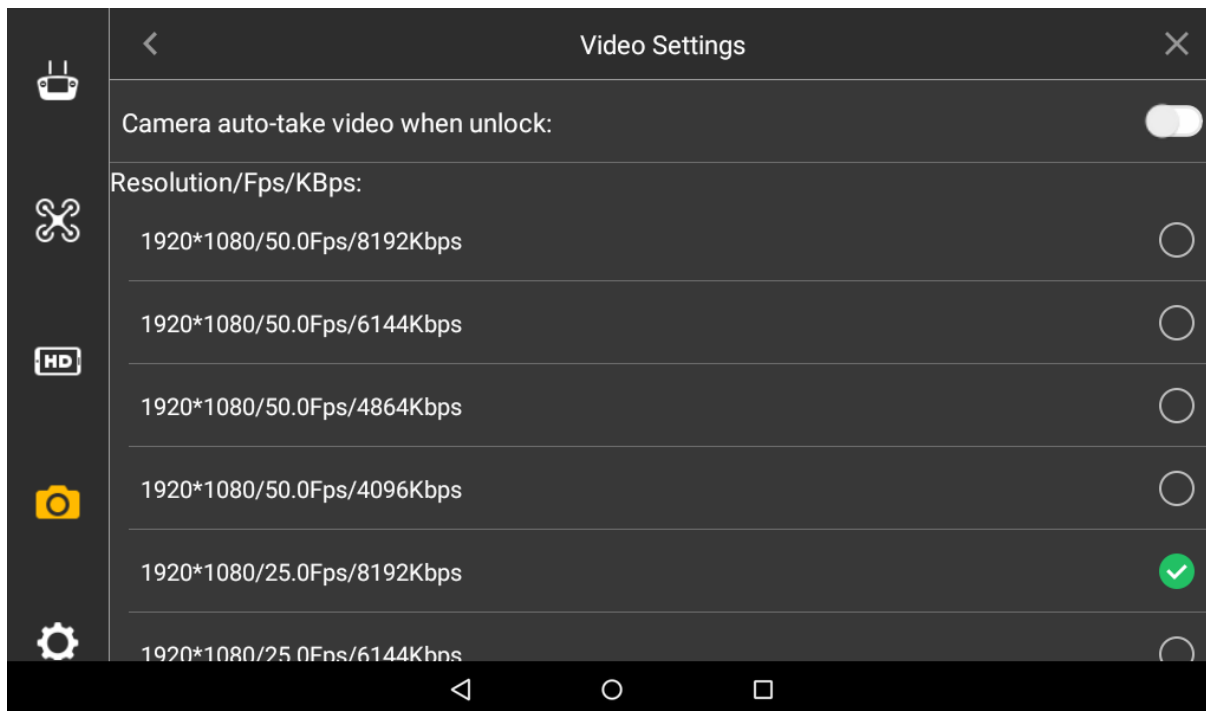

Figure 4-29

- Step 2 Select the switch behind “Camera Auto-take Video When Unlock”. When the switch turns green and ticked, it means that the function is enabled.
- Step 3 Select “Resolution/FPS/KBps”, click a line, and icon at the end of selected parameter line becomes green and checked, which makes it valid immediately.
- Step 4 Select “Stream Format”, as shown in Figure 4-30.

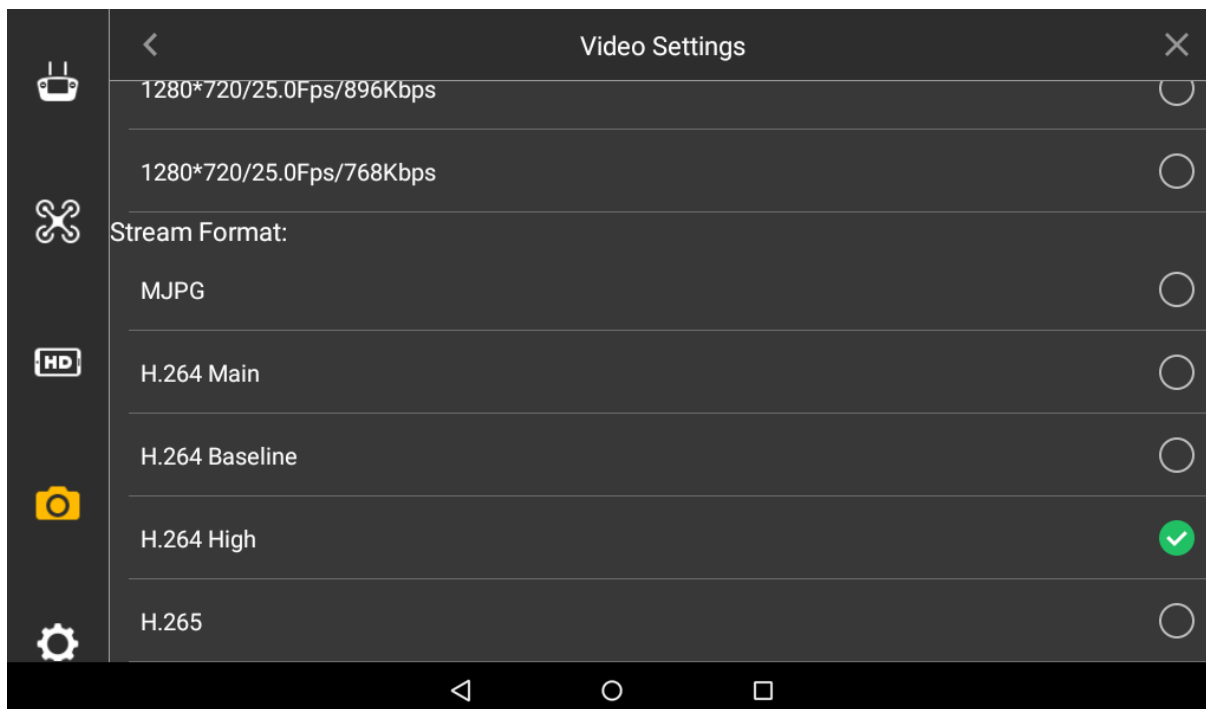

Figure 4-30

- Step 5 Click a line, and icon at the end of selected parameter line becomes green and checked, which makes it valid immediately.
- MJPG: In this mode, video image needs relatively high stream value to guarantee definition. To obtain a good effect, it is suggested to use maximum stream value

- among reference stream value.
- H.264 Main: Main Profile mode.
- H.264 Baseline: Baseline Profile mode.
- H.264 High: High Profile mode.
- H.265: Main Profile mode.

### 4.5.4.3 Image Settings

Set the brightness, contrast, saturation, sharpness and gamma value of the preview image of PTZ camera.

- Step 1 Select “Settings > Camera Settings > Advanced Settings > Image Settings”.
- The system displays “Image Settings” interface, as shown in Figure 4-31.

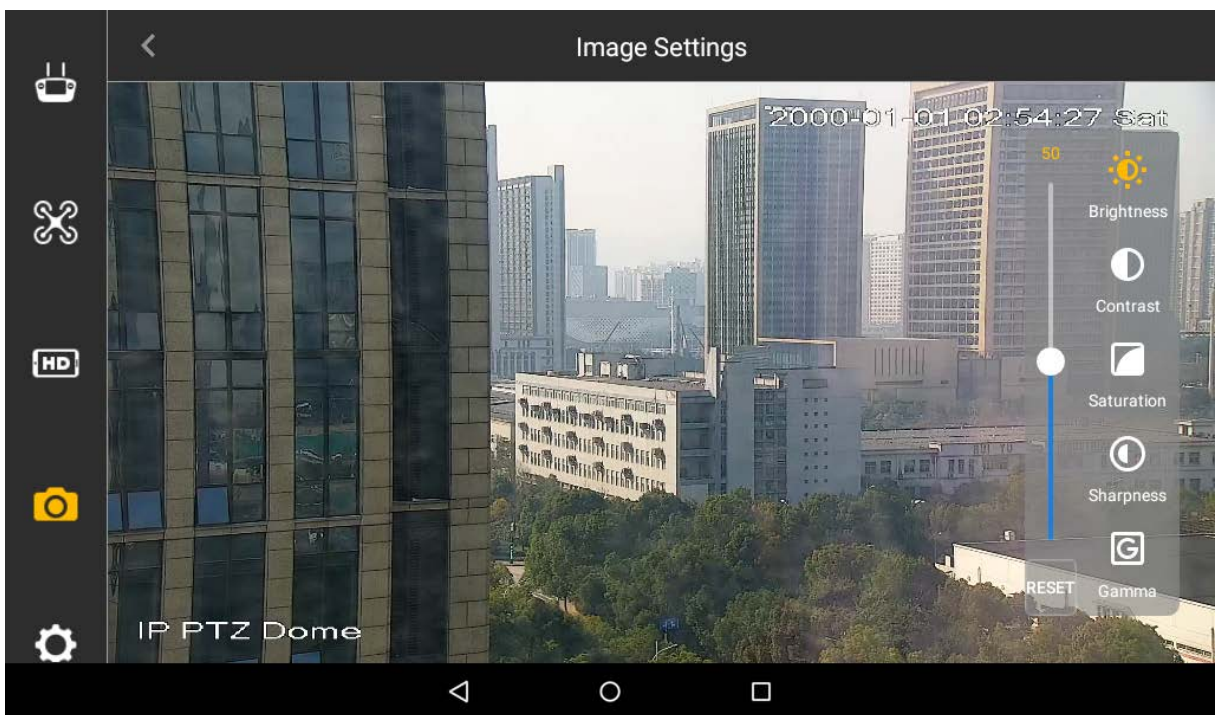

Figure 4-31

- Step 2 Set the parameter items on the right of the interface.
- Brightness: Adjust the overall brightness of the image; adjust the value when the overall brightness of image is too bright or too dark.
  - Contrast: Adjust the image contrast. Adjust the value when overall brightness is proper but the image contrast is not enough.
  - Saturation: Adjust the bright degree of the color, which will not affect the overall brightness of the image.
  - Sharpness: Adjust the image resolution and sharpness degree of image edge.
  - Gamma: Optimize brightness and contrast, and adjust slight brightness and darkness layer of the image.

- Step 3 Set parameter value by sliding, and it is valid immediately.

### 4.5.5 General Settings

Realize firmware update and other settings, including brightness, date and time, network setting, language and Micro SD card setting.

## 4.5.5.1 Other Settings

### 4.5.5.1.1 Network Settings

Network access of remote control includes Wi-Fi, mobile hotspot and 4G.

Step 1 Select “Settings > General Settings > Other Settings > Network Settings”.

The system displays “Network Settings” interface, as shown in Figure 4-32.

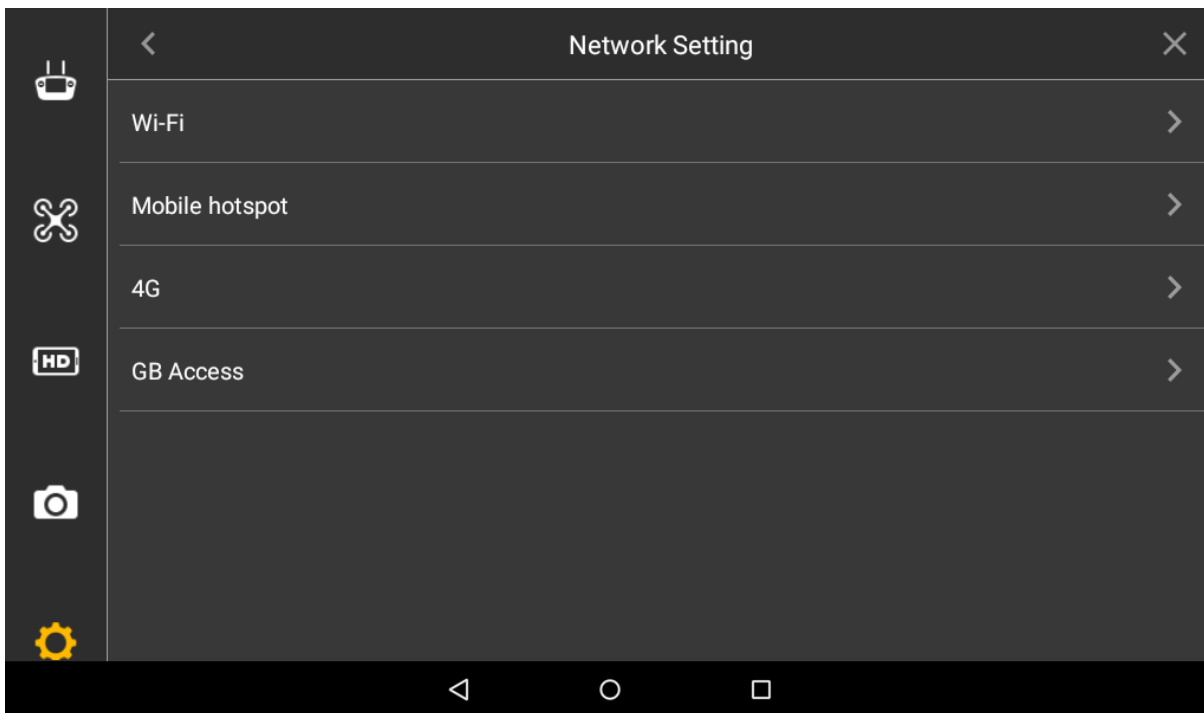

Figure 4-32

Step 2 Select “Network Setting”.

- Wi-Fi: Enable “WLAN”, connect the remote control with wireless network, and thus transmit data through wireless network.
- Mobile hotspot: Enable “Mobile WLAN Hotspot”, so the user’s mobile phone or other devices are connected with the network through mobile hotspot.
- 4G: Select “Connect”, enable 4G mode of the remote control and connect the remote control with 4G network.

### 4.5.5.1.2 Micro SD Settings

View total space of Micro SD card and the space occupied by every part.

Select “Settings > General Settings > Other Settings > Micro SD Card Settings > Storage Settings”. The system displays “Storage Settings” interface, as shown in Figure 4-33.

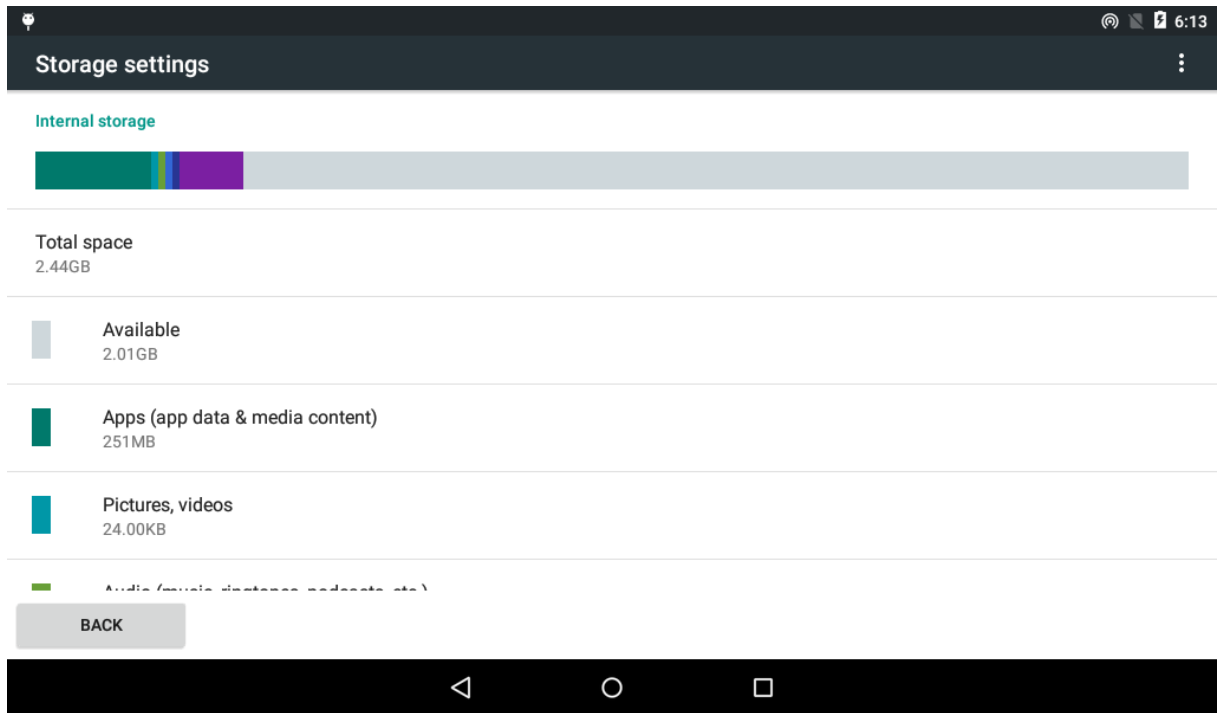

Figure 4-33

#### 4.5.5.1.3 Brightness

Set the overall display brightness of the remote control touch screen.

Step 1 Select “Settings > General Settings > Other Settings > Brightness”.

The system displays “Brightness” interface, as shown in Figure 4-34.

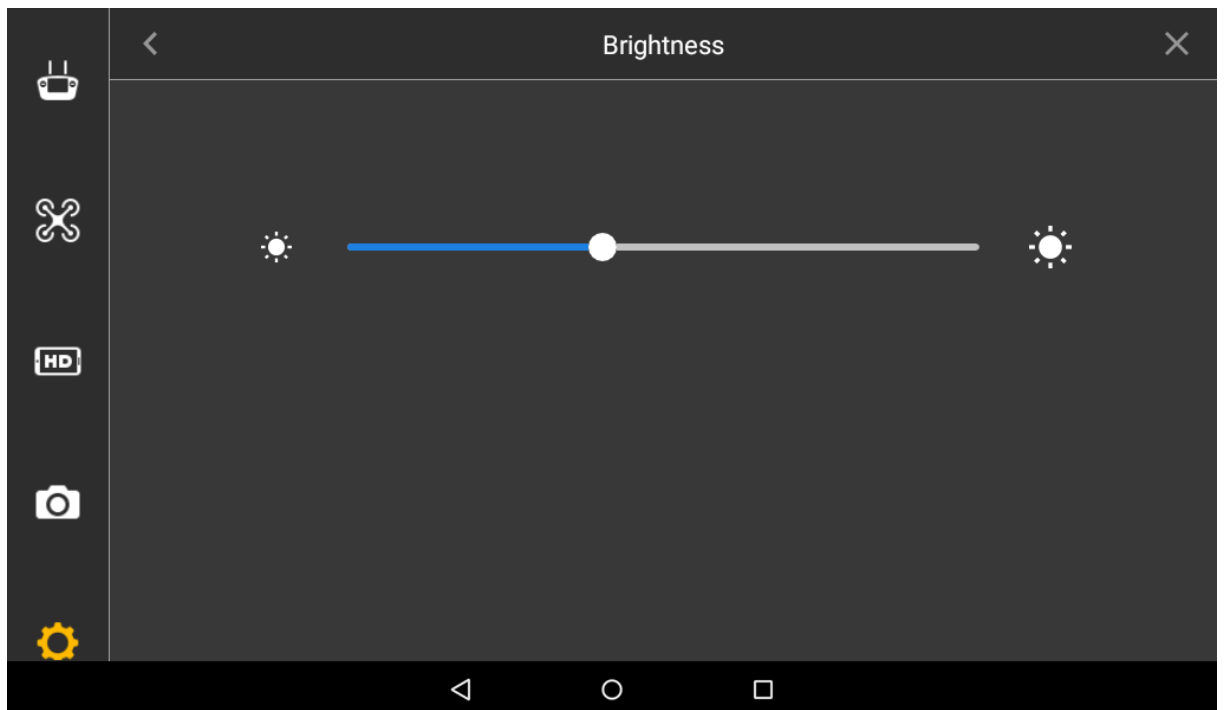

Figure 4-34

Step 2 Drag the adjustment bar to set overall brightness of remote control.

It becomes darker when the adjustment bar moves left, and becomes brighter when it moves right.

#### 4.5.5.1.4 Date and time

Set the date, time and time zone displayed on the remote control.

Step 1 Select “Settings > General Settings > Other Settings > Date and Time”.

The system displays “Date and Time” interface, as shown in Figure 4-35.

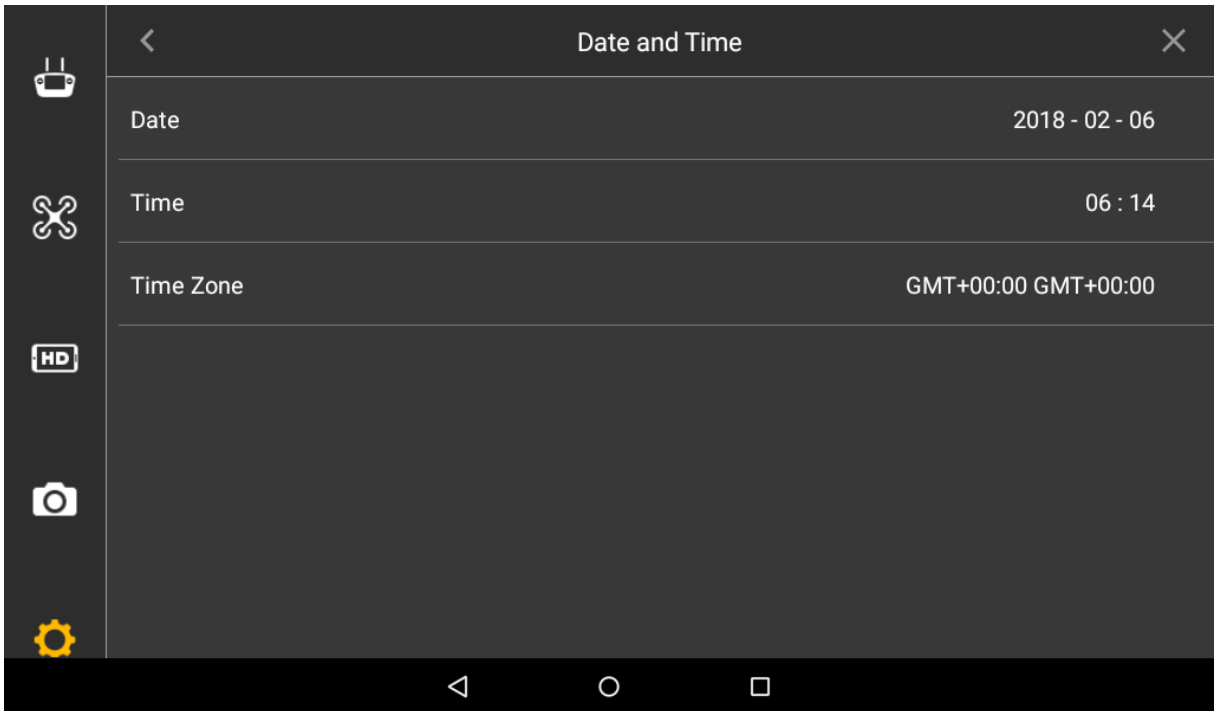

Figure 4-35

Step 2 Set parameters according to actual needs. Please refer to Table 4-3 for more details.

Parameter	Note
Date	Click it to set date of remote control.
Time	Click it to set time of remote control.
Time Zone	Click it to set present time zone of remote control.

Table 4-3

#### 4.5.5.1.5 Language

Set the language displayed on the remote control.

Step 1 Select “Settings > General Settings > Other Settings > Language”.

The system displays “Language” interface, as shown in Figure 4-36.

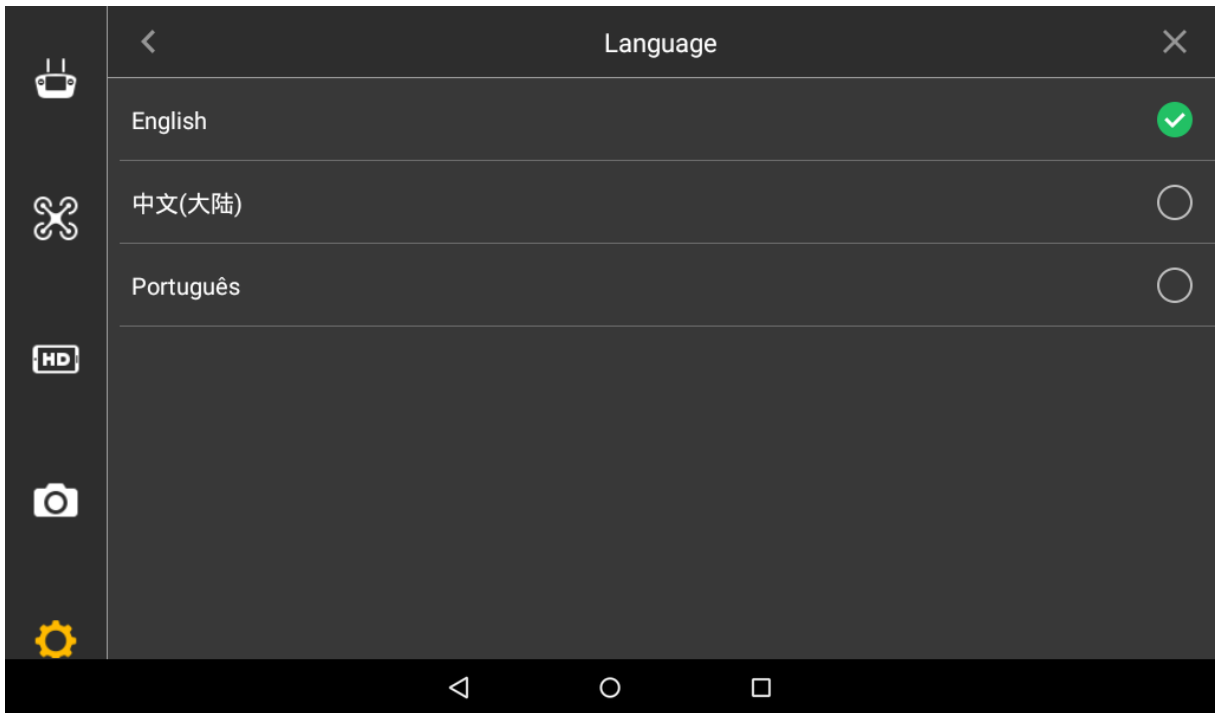

Figure 4-36

Step 2 According to actual needs, select English or Chinese.

#### 4.5.5.2 About

View hardware device model and version info.

Select “Settings > General Settings > About” to enter “About” interface, as shown in Figure 4-37.

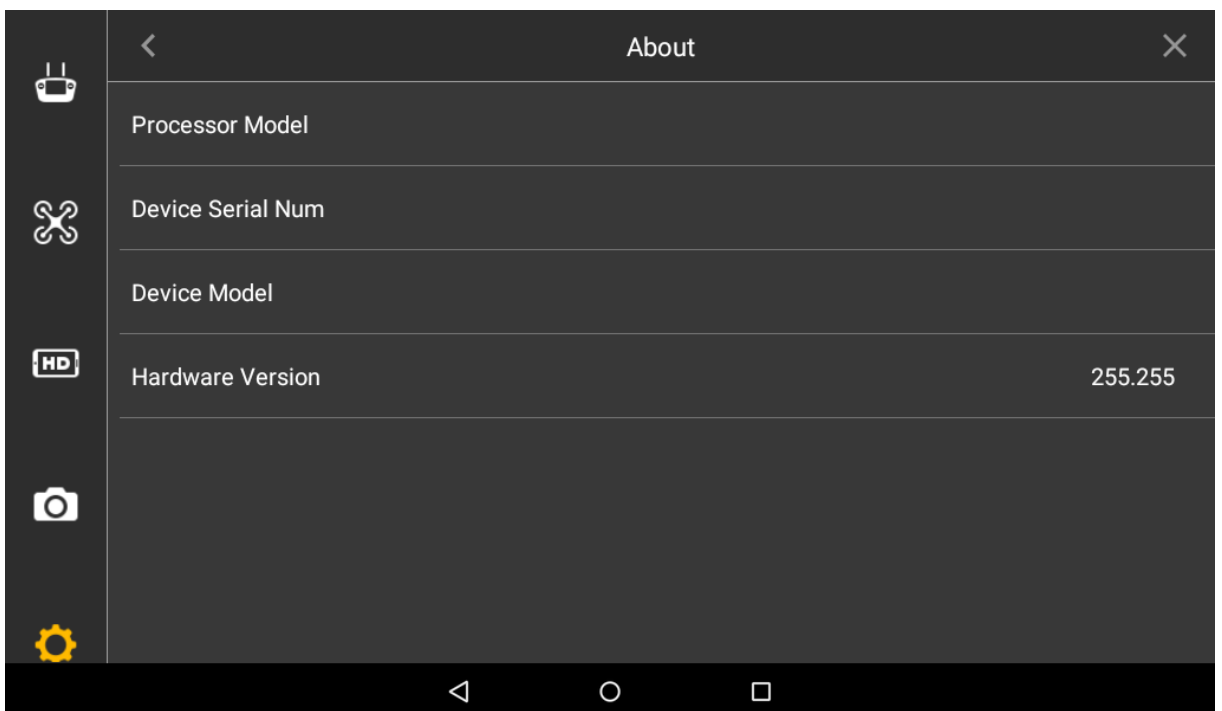

Figure 4-37

# 5 End Flight



This chapter elaborates the operation steps after aircraft landing.

Please operate according to the following flows to make sure normal application for the next time. Some of the operations are not indispensable. Please select according to the actual situation.

End Flight

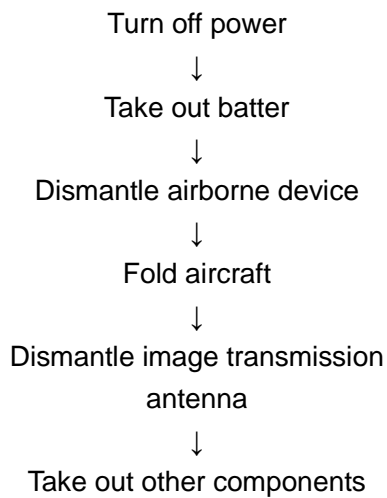

Figure 5-1

## 5.1 Turn off Power



It has to turn off the aircraft power first, and then turn off the power of remote control.

Step 1 Short press the power switch of aircraft battery. It means that the aircraft power has been turned off when the built-in indicator light of the switch is off.

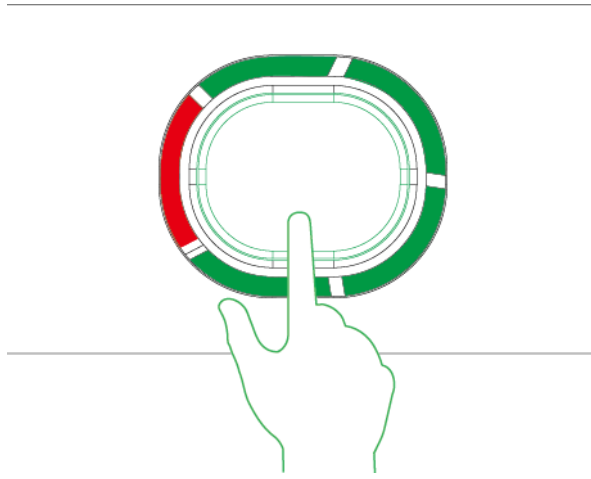

Figure 5-2

Step 2 Move the power switch on the rear panel of the remote control to the other side. It means that remote control power has been turned off when the indicator light of remote control front panel is off.

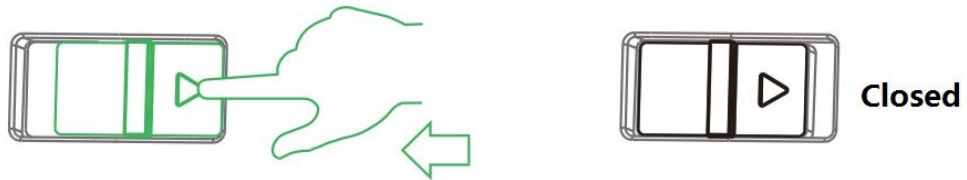

Figure 5-3

## 5.2 Remove Aircraft Battery

Step 1 Open the battery buckle of the aircraft, as shown in Figure 5-4.

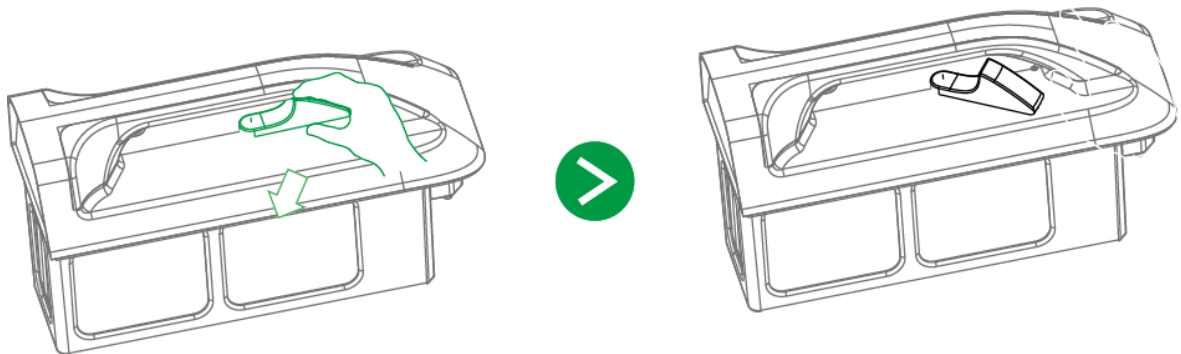

Figure 5-4

Step 2 Lift the battery from the compartment, as shown in Figure 5-5.



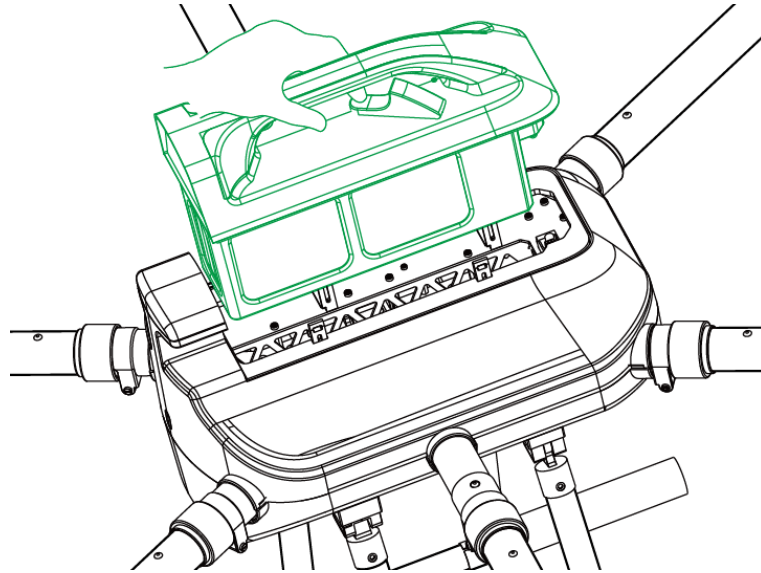

Figure 5-5

## 5.3 Dismantle Airborne Device

Step 1 Loosen 4 mounting screws, as shown in Figure 5-6.

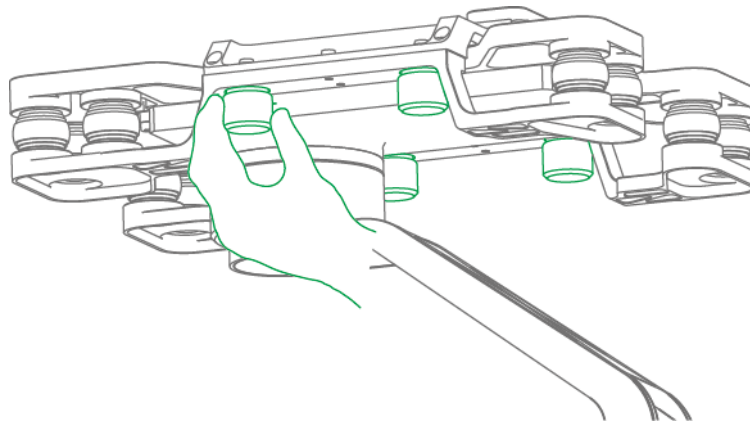

Figure 5-6

Step 2 Dismantle PTZ camera.

## 5.4 Fold Aircraft

Step 1 Press the spring fastener on both sides of the propeller center, and remove the propeller, as shown in Figure 5-7.

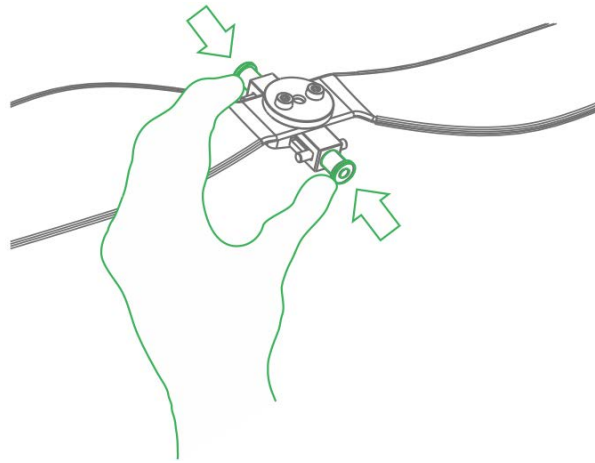

Figure 5-7

Step 2 Restore the antenna and keep it close to the arm, as shown in Figure 5-8.

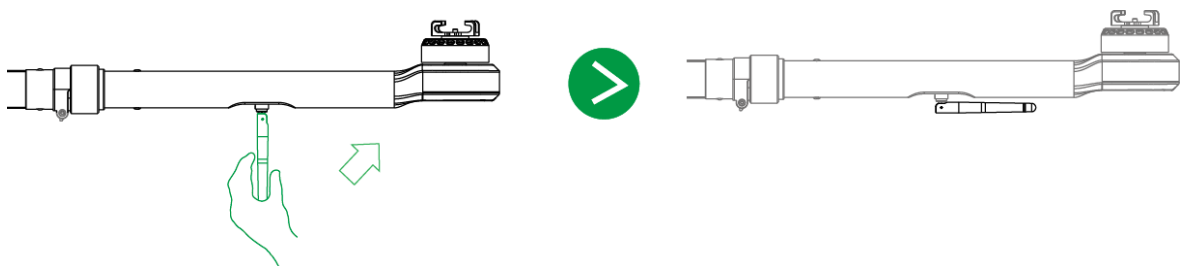

Figure 5-8

Step 3 Hold the arm with left hand, loosen helical casing with right hand and lay down the arm gently, as shown in Figure 5-9.

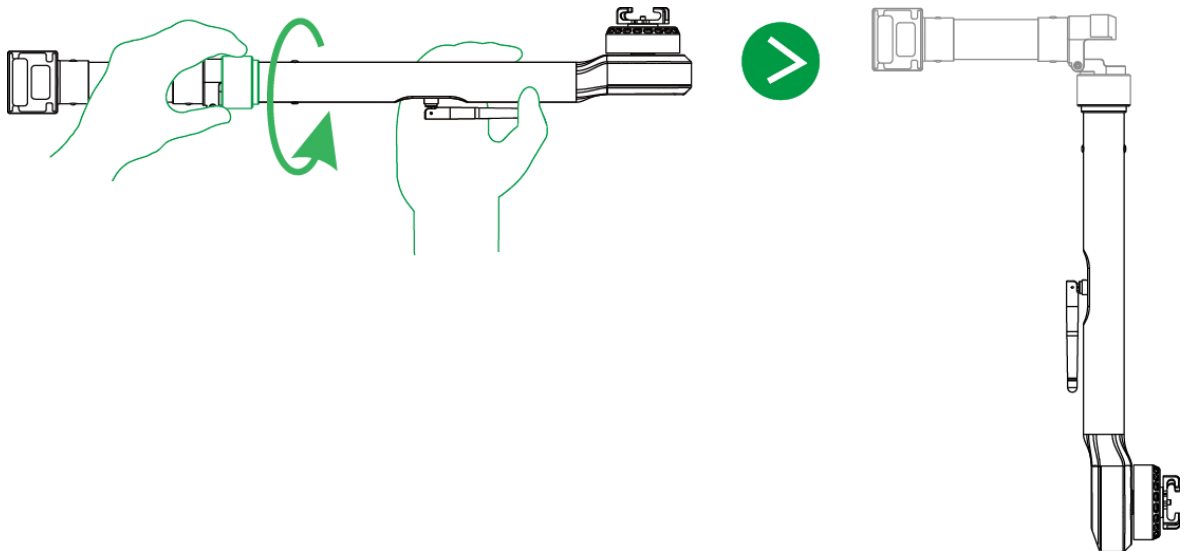

Figure 5-9

## 5.5 Copy Video of Camera Micro SD Card

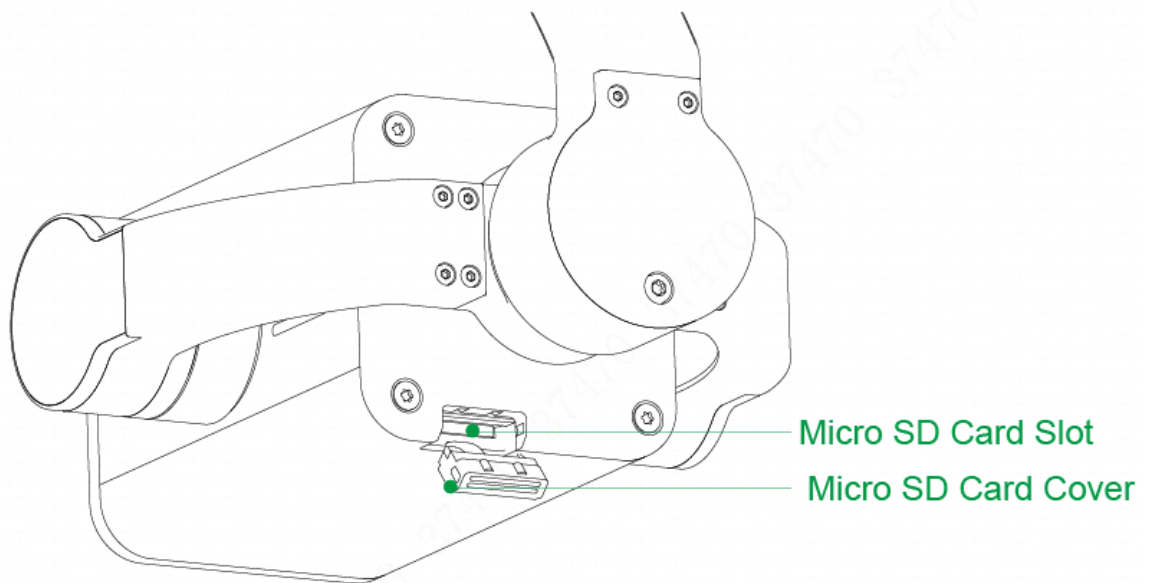

Figure 5-10

- Step 1 Open micro SD card plug with hands.
- Step 2 Slightly press micro SD card and it will pop out. Pull out the micro SD card.
- Step 3 Insert the micro SD card into the card reader, and connect the card reader to computer.  
Copy the micro SD card video into the computer via card reader and save it.

## 5.6 Remove Other Components

- Remove SIM card: open silicone cover of side panel, pull out SIM card and close the silicone cover.
- Fold remote control antenna: Fold the antenna and make it close to the front panel of remote control.

# 6

## Upgrade and Update

This chapter elaborates upgrade methods of the device.

### 6.1 Firmware Update

#### Note

The aircraft and remote control have to be enabled and connected during firmware update, which is to make frequency matched.

#### Warning

Don't upgrade the firmware during flight!

Update flight control, transmitting and receiving firmware of the aircraft, as well as transmitting and receiving firmware of the remote control.

Step 1 Insert the micro SD card with firmware update package into the micro SD card slot of the remote control.

Step 2 Select "Remote Control > Settings > General Settings".

The system displays "Firmware Update" interface, as shown in Figure 6-1.



Figure 6-1

Step 3 Select "Update Now".

The system starts to update the firmware.

#### Note

If micro SD card isn't inserted, it will display the latest version on the right of each firmware.

### 6.2 Remote Control Update

#### 6.2.1 APP Update

Step 1 Insert the micro SD card with APP update package into the micro SD card slot of the remote control.

Step 2 Select "Settings > General Settings".

It will display the current APP version number or update software on the right of "APP Update", as shown in Figure 6-2.

Figure 6-2

- It doesn't need to update when it displays the version number, and it means that the current APP is the latest version.
- Update is available when it displays "Update Now".

Step 3 Select "Update Now".

Update automatically and display update progress.

After successful update, version number in the above figure will be the same as update software.

## 6.2.2 Download and Update Offline Map of Remote Control

Step 1 Insert 4G-SIM card or connect Wi-Fi, so the remote control accesses the network.

Step 2 Select "Settings > General Settings > Other Settings > Offline Map".

The system displays the interface of "Offline Map", as shown in Figure 6-3.

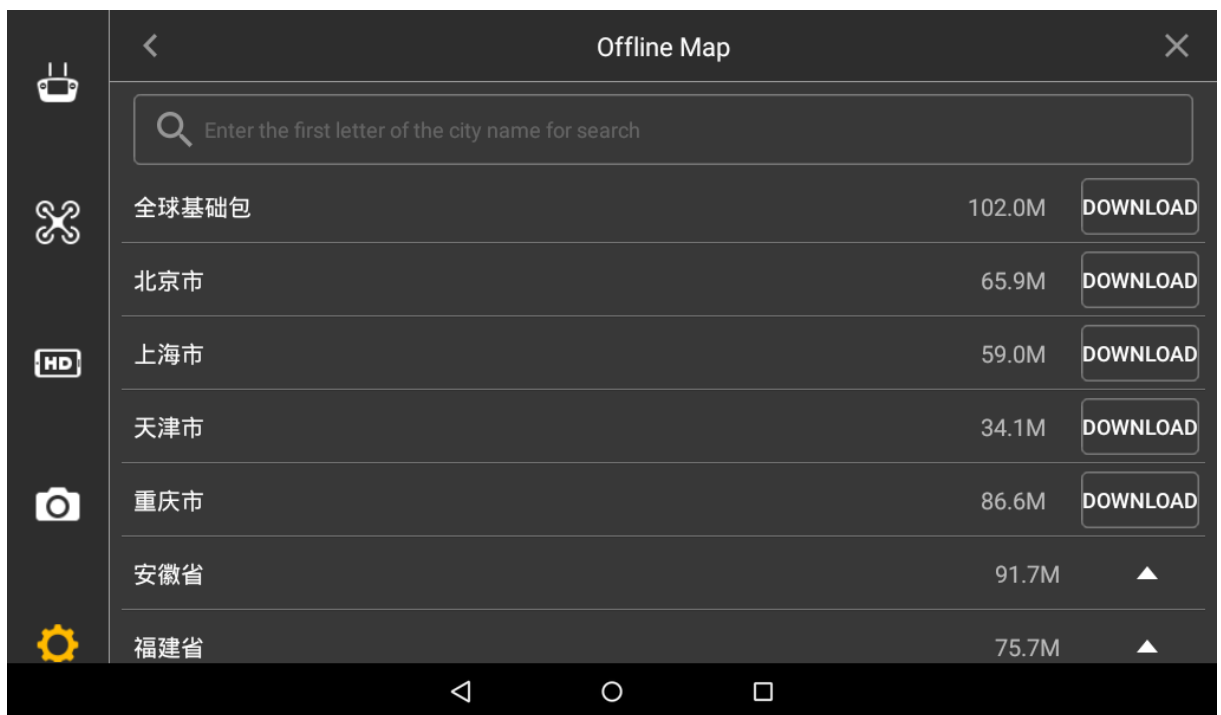

Figure 6-3

Step 3 Select the city which needs to be updated, and then click "Download" button in the right.

Step 4 The map takes effect immediately, without need for other operations.

## Appendix 1 Main Technical Parameters

Parameter Item		Parameter Value
Model		Navigator X1100
System	Operating temperature	-20℃~60℃
Environment Adaptability	Operating humidity	Operating humidity is 95%, non-condensation.
Aircraft	Wheel base	1100mm
	Aircraft type	6 rotor wings
	Mechanical features of arm	Foldable
	Landing gear	Retractable with remote control
	Rack weight (except battery and load, only power system)	6000g
	Takeoff weight	9600g~14500g
	Satellite positioning module	GPS
	Max. flight altitude	No less than 5000m
	Battery	6S LiPo 27000mAh intelligent battery
	Max hovering time	35min (mounted with 2-megapixel PTZ camera)
	Intelligent obstacle avoidance	Support
Power System	Propeller wing material	Carbon fiber
	Propeller wing dimension	19.5 inchesx7 inches
	Mechanical features of propeller wing	Quick demount
Flight Control	Hovering accuracy (relative accuracy)	<ul style="list-style-type: none"> <li>● Horizontal: ±0.2m</li> <li>● Vertical: ±0.5m (weaker than gentle breeze)</li> </ul>
	Wind resistance capacity	6 wind scale
	Max. attitude angle velocity	<ul style="list-style-type: none"> <li>● Course: 150°/s</li> <li>● Pitch: 250°/s</li> </ul>
	Max. attitude angle	25°
	Cruising speed	10m/s
	Built-in function	<ul style="list-style-type: none"> <li>● Fixed elevation, fixed point, autonomous cruise and several other flight modes</li> <li>● Auto takeoff and landing</li> <li>● Low voltage protection</li> <li>● Auto RTH</li> <li>● Preset no-fly zone</li> <li>● Electronic fence</li> <li>● Protection in case of broken propeller</li> <li>● Intelligent obstacle avoidance /optical flow positioning</li> <li>● LED APP prompt</li> </ul>
PTZ	Weight (including load)	880g

Parameter Item		Parameter Value
Model		Navigator X1100
	Angle control accuracy	±0.01°
	Max. controllable rotation speed	<ul style="list-style-type: none"> <li>● Course: ±130°/s</li> <li>● Pitch: ±130°/s</li> </ul>
	Controllable rotation range	<ul style="list-style-type: none"> <li>● Course: ±168°</li> <li>● Pitch: -90° to +45°</li> </ul>
	Installation mechanical feature	Quick mount and demount
	Built-in function	<ul style="list-style-type: none"> <li>● Two working modes: <ul style="list-style-type: none"> <li>◇ Course follow mode</li> <li>◇ Attitude lock mode</li> </ul> </li> <li>● Built-in independent IMU module</li> <li>● X1100 exclusive servo drive module</li> <li>● Ethernet video transmission and camera PTZ control</li> </ul>
Visible Light Camera (2 MP, 30X optical zoom)	Sensor	1/1.8" 3Mp CMOS
	Max resolution	1920 (H) ×1080 (V)
	View angle	67.8°~2.77°
	WDR	≥100dB
	Video compression standard	H.264/H.265/MJPEG
	Frame rate	30fps@5M/3M, 60fps@1080p
	Iris	F1.6~F4.4
	Focal length	4.5mm~135mm (30x optical zoom)
	Digital NR	3D
	SNR	≥55dB (AGC Off, Weight ON)
	Min illuminance	<ul style="list-style-type: none"> <li>● Color: 0.005Lux@F1.6</li> <li>● Black and white: 0.0005Lux@F1.6</li> </ul>
	Backlight compensation mode	BLC/HLC
	Day/night switch	Auto/Manual
	WB	Auto/Manual/Tracking/Outdoors/Indoors/Outdoors Auto/Sodium Lamp Auto/Sodium Lamp
Electronic shutter	Support auto electronic shutter (1/3~1/30,000s), manual electronic shutter (1/3~1/30,000s).	
Storage	128GB Micro SD	
Thermal camera (temperature measuring type)	Detector type	Uncooled vanadium oxide focal plane detector
	Detector pixel	640×512
	Video coding	H.264M/H.264H/M-JPEG, support 720P image output
	Pixel size	17μm
	Spectral range	7.5μm~13.5μm
	Thermal sensitivity	≤40mK
	Lens focal length	19mm
	Distance (human:	640m, 160m, 80m

Parameter Item		Parameter Value
Model		Navigator X1100
	1.8m*0.5m, detection, recognition, identification)	
	Distance (vehicle: 2.3m*2.3m, detection, recognition, identification)	2000m, 500m, 250m
	Temperature measuring range	Low temperature mode: -40°C to 160°C. High temperature mode: -40°C to 550°C
	Temperature measuring error	Max( $\pm 2^{\circ}\text{C}$ , $\pm 2\%$ )
	Temperature measuring function	Support real-time multi-preset temperature measuring, temperature alarm, temperature correction, temperature measuring unit setting, temperature real-time analysis, historical temperature information query and so on.
	Storage	128GB Micro SD
	Integrated remote control	Features
Remote control distance		$\geq 5\text{km}$
Remote control dimension		350mm $\times$ 228mm $\times$ 85mm
Battery		2S LiPo, 7800 mAh
Output port		micro USB, headset port
Operating screen and system		<ul style="list-style-type: none"> <li>● Screen size: 7" (Multi-point capacitance)</li> <li>● Resolution:1024*600</li> <li>● OS: Android 5.1</li> </ul>
Network		WiFi IEEE802.11 b/g/n
Storage		16GB Micro SD
Protocol		GB/T 28181

Appendix Table 1-1



## Appendix 2 Aircraft State Indicator

The aircraft status indicator over the power switch is turned on after the aircraft is enabled. Different colors and statuses mean differently. Please refer to the Appendix Table 2-1.

Please do understand the contents listed in the table below before flight, which is to help you quickly understand the aircraft status or positioning problem during flight. The actual operation methods will be specifically introduced in other chapters.

Phase	Indicator color and status	Implication	Operation	
Startup	●●● ●●● ●●●...	Self-check and preheating	Wait	
	●Normally on	System self-check report error	-	
	● ● ●...	Aircraft in no-fly zone	Move the aircraft out of no-fly zone.  <b>Note</b> Please refer to “3.8 Check and Debugging” for the flight area.	
Compass calibration	●Normally on	Horizontal calibration of compass	Wait	
	●Normally on	Vertical calibration of compass	Wait	
	●● ●● ●●...	Calibration failure of compass	Manually calibrate compass	
Pair	●Normally on	Pairing success	-	
Flight	● ● ●...	Take off normally	-	
	●Flash once	fixed point mode and satellite number $\geq$ 6	-	
	●Flash twice	fixed point mode and satellite number $<$ 6	-	
	●Flash once	Intelligent mode and satellite number $\geq$ 6	-	
	●Flash twice	Intelligent mode and satellite number $<$ 6	-	
	●Flash once	Fixed altitude mode	-	
	●●● ●●● ●●●...	-	Disconnected from remote control for more than 3s	-
	●●● ●●● ●●●...	-	Level 1 low battery warning	-
	●●●● ●●●● ●●●●...	-	Level 2 low battery warning	-
	●●●● ●●●● ●●●●...	-	Disconnected from remote control for more than 3s	-

Phase	Indicator color and status	Implication	Operation	
	●●●● ●●●● ●●●●...		Level 1 low battery warning	-
	●●●●● ●●●●● ●●●●●...		Level 2 low battery warning	-
	●●● ●●● ●●●...		Disconnected from remote control for more than 3s	-
	●●● ●●● ●●●...		Level 1 low battery warning	-
	●●●● ●●●● ●●●●...		Level 2 low battery warning	-
	●●● ●●● ●●●...	Return	Image transmission disconnected	-
	●●●● ●●●● ●●●●...		Disconnected from remote control for more than 3s	-
	●●●● ●●●● ●●●●...		Level 1 low battery warning	-
	●●●●● ●●●●● ●●●●●...		Level 2 low battery warning	-
	●●● ●●● ●●●...		Disconnected from remote control for more than 3s	-
	●●● ●●● ●●●...		Level 1 low battery warning	-
	●●●● ●●●● ●●●●...		Level 2 low battery warning	-
	●● ●● ●●...		Firmware upgrade in progress	Wait
	●Normally on		Upgrade failed	Check upgrade step. Upgrade again
●Normally on	Upgrade succeeded	-		
Lose efficacy	●Flash for three times	Any sensor loses efficacy and any abnormal forced landing events	-	

Appendix Table 2-1

## Appendix 3 System Pairing



Caution

The frequency of aircraft and remote control has been paired before factory delivery.

### Abnormity

It needs to pair again when the remote control relation between remote control and aircraft loses effect.

### Specific Operations

Step 1 Open silicone cover of USB port of the aircraft.

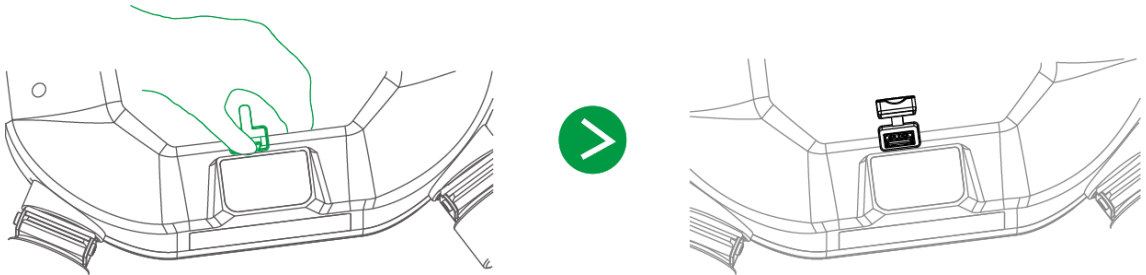

Appendix Figure 3-1

Step 2 USB2.0 port at the other end of data cable shall be inserted into USB port of the aircraft.

Step 3 MicroB port of data cable shall be inserted into Micro USB port of the remote control. Complete connection of the aircraft and remote control, as shown in Appendix Figure 3-2.

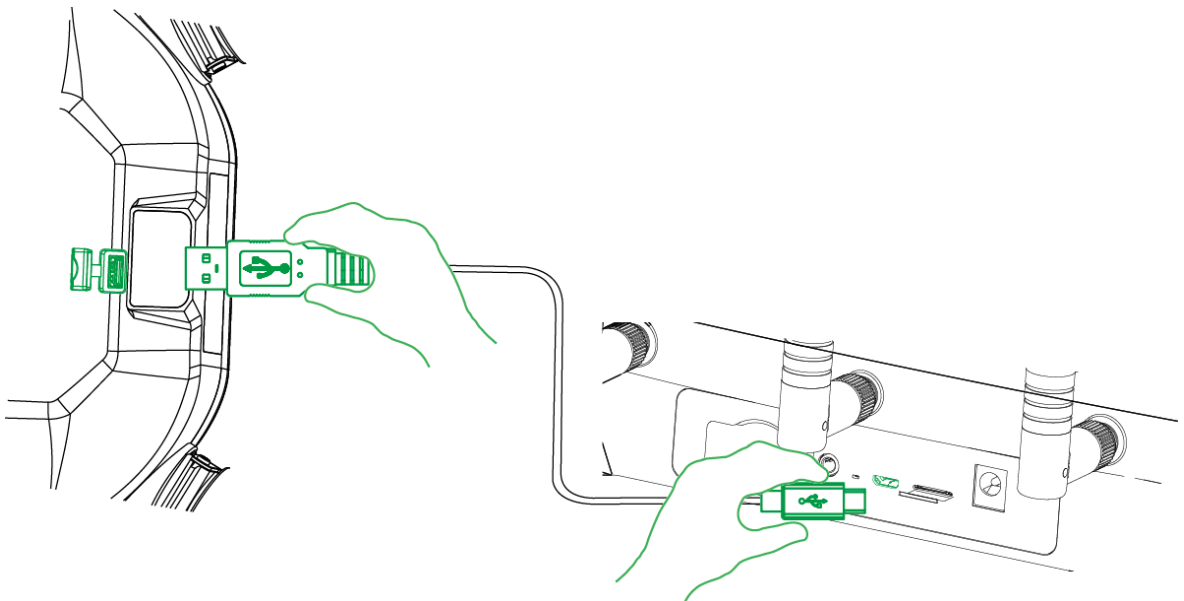

Appendix Figure 3-2

Step 4 Select “Settings > Remote Control Settings > Remote Pair” on the remote control.  
The system displays the interface of “Remote Pair”, as shown in Appendix Figure 3-3.

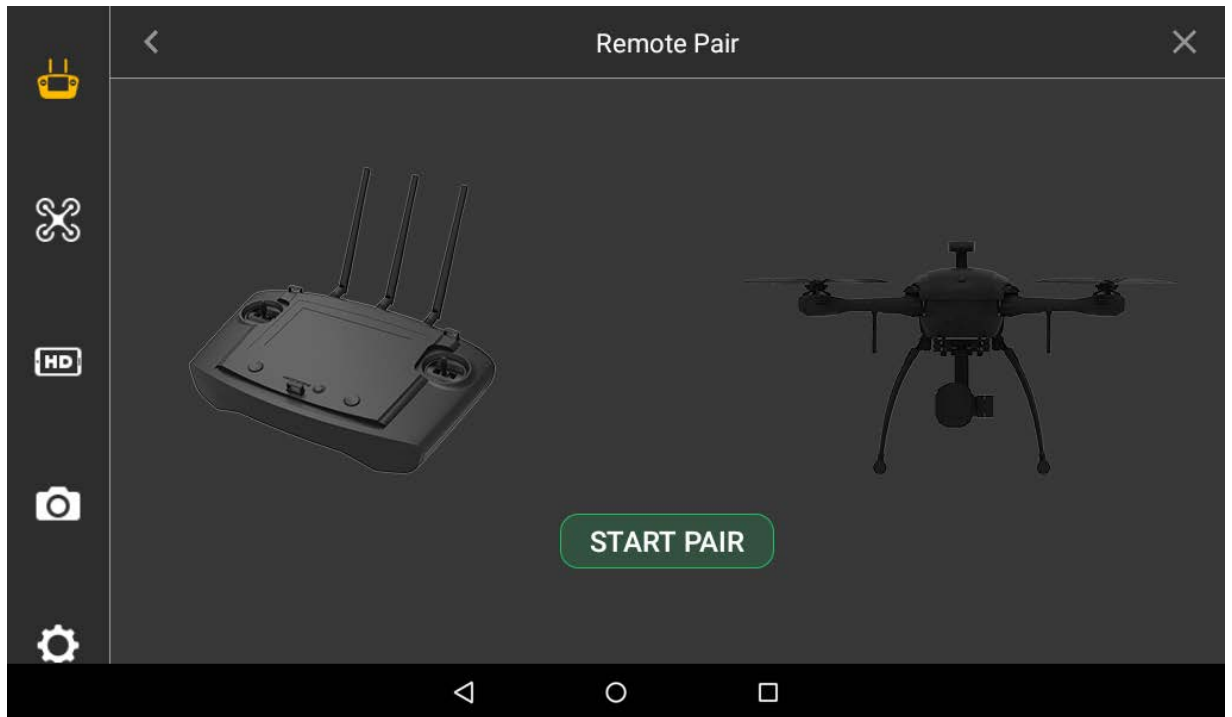

Appendix Figure 3-3

Step 5 Click “Start Pair” on the remote control, and the system starts pairing automatically.

Step 6 It means pairing is successful when the remote control prompts “Success”.

Step 7 If the interface prompts pairing failure, click “Retry” and repeat above step 1-4.

### Appendix 4.1 FAQ and Solutions of Aircraft

Question: Images are subject to water ripple and jitter in case of gale.

Solution: Prevent PTZ from facing the gale directly.

### Appendix 4.2 FAQ and Solutions of Remote Control

Question: Response speed of remote control touch screen becomes slow and has other abnormalities.

Solution: Restart the remote control with power switch at the back of remote control. Please timely contact the supplier if it is not improved.

### Appendix 4.3 FAQ and Solutions of Airborne Device

Question: Recorded video loss (including failure to copy data from micro SD card).

Solution: Check the aircraft version. Please contact the supplier if the version is too low.

### Appendix 4.4 FAQ and Solutions of Charger

Question: Charger displays error prompts: ERR1 (Starting Connection Error), ERR2 (Current Abnormity Protection), ERR3 (Balance Port Fault), ERR4 (AC Input Fault) and ERR5 (Charging Connection Error).

Solution: Please inspect whether connection between AC power line and charger, or connection between charger and battery is abnormal or not. Please contact the manufacturer if it fails to be solved.



Address: No.1199, Bin'an Road, Binjiang District, Hangzhou, P.R. China

Postcode: 310053

Tel: +86-571-87688883

Fax: +86-571-87688815

Email: [overseas@dahuatech.com](mailto:overseas@dahuatech.com)

Website: [www.dahuasecurity.com](http://www.dahuasecurity.com)